

# HD/EX MOUNT KIT 16062190B

GM 2500/3500  
2020+



## **SnowDogg® Snowplow**

# TRUCK MOUNT INSTALLATION MANUAL

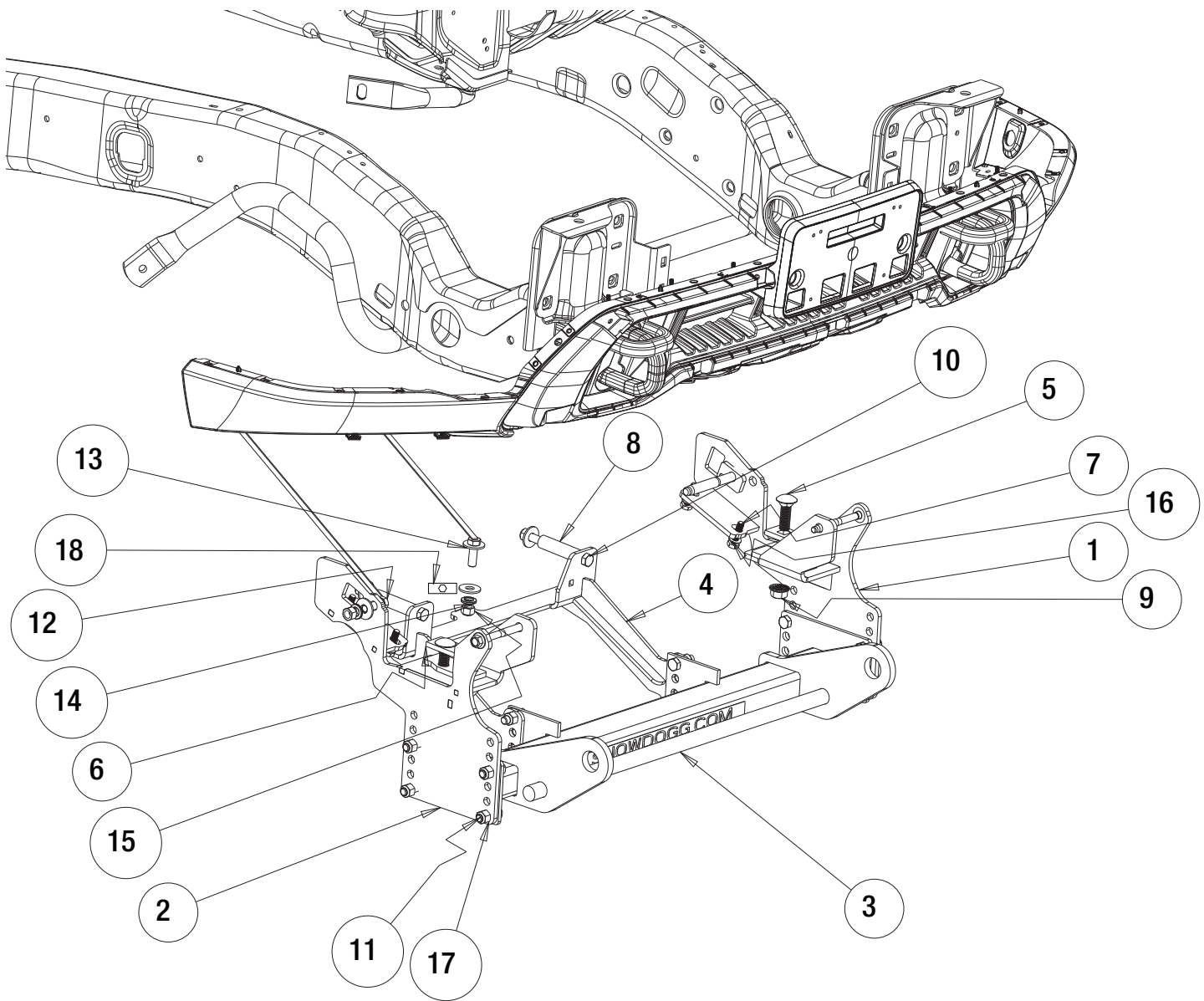

**Bill of Materials**

ITEM	PART NO.	QTY.	DESCRIPTION
1	16062198	1	SIDEPLATE, DS, WELD, 20GM
2	16062194	1	SIDEPLATE, PS, WELD, 20GM
3	16062196	1	PUSHBAR, FORD F150 09+ HD
4	16062193	1	CTR BRACKET, 20GM 2500
5	3038887	2	CARRIAGE BOLT, 5/8-11 X 2IN, G8
6	3039525	2	RECTANGLE, SQ HOLE 5/8 X 2.5 IN L
7	3017707	4	SCREW, M10-1.5X40MM
8	3017702	2	SPACER, TUBING 3.45 LONG
9	3038931	2	NUT, HEX, SERR, FLGE, 5/8-11, G8, ZN
10	3011255	4	SCREW, HEX HD - 1/2-13 X 5 GR 8 ZC

ITEM	PART NO.	QTY.	DESCRIPTION
11	3006202	12	SCREW, HEX HD - 1/2-13 X 1-1/2 GR 8 ZC
12	16801004	13	SCREW, HEX HD, 1/2-13x1-1/2 GR 5 W/ HDL
13	FWF050138014	5	WASHER, FLAT, 1/2" USS, ZN
14	FWL050088013	2	WASHER, LOCK - 1/2 SPLIT ZN
15	3006201	2	NUT, 1/2-13 HEX GR. 8 ZP
16	FWF038081006	4	WASHER, FLAT 3/8 SAE ZINC
17	FWF038081006	16	LOCKNUT, HEX NYLOCK, 1/2-13 ZN, G8
18	16061121	1	NUT PLATE WITH HANDLE
19	3051981	1	M16-2 x 140MM CL 8.8

## INSTRUCTIONS

1. It is not necessary to remove the bumper for this installation. The lower-center-front plastic cover can be removed with some small removable fasteners. The plastic can be modified to make room for the push-bar clearance.
2. Remove the skid plate attached from the round cross bar to the cross member of the frame. The skid plate will have to be modified or omitted for this installation.
3. Lower the two sway bar brackets from the bottom of the truck by removing the four bolts from PS and DS frame.

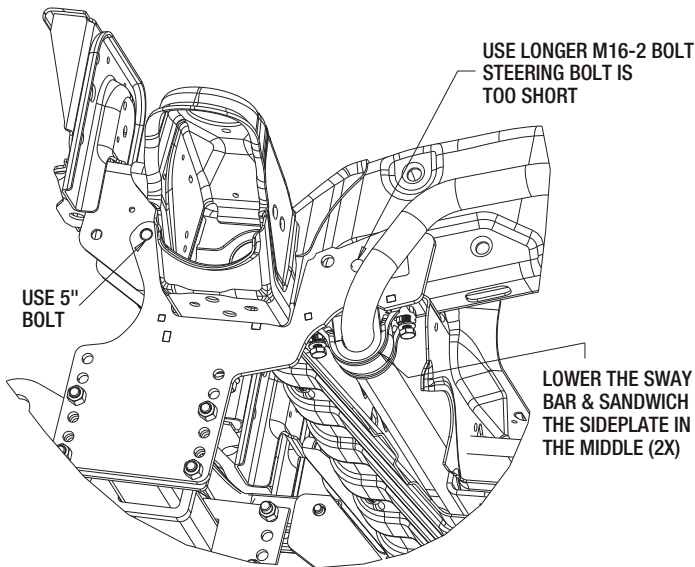

4. Hold the DS side plate (1) against the frame aligning it to the towhook holes. Using the existing bolts, secure the bracket to the frame of the truck. Raise the sway bar bracket up to its original position and secure the sway bar bracket to the bottom of the Side plate. Use the longer M-10 bolts provided if your bolts are shorter.
5. Secure the bottom of the side plate to the frame. In some models, re-use the bottom tow hook bolt at the bottom of the side plate. If not, use the 5/8 carriage bolts and nut provided. On the upper right of the side plate, use the long 5" bolt provided since the tow-hook bolt is too short.

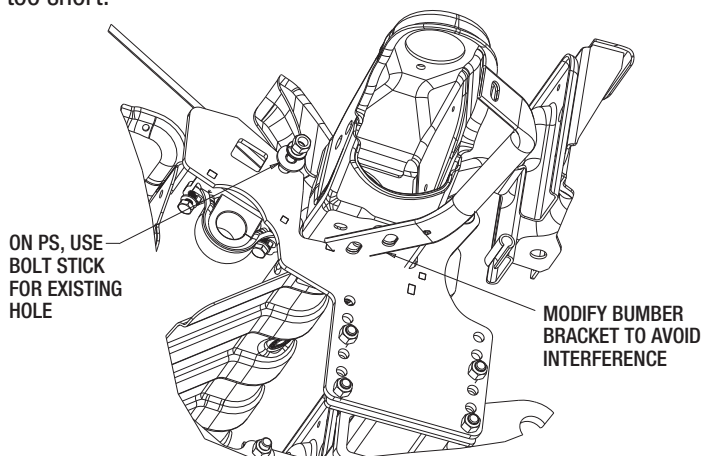

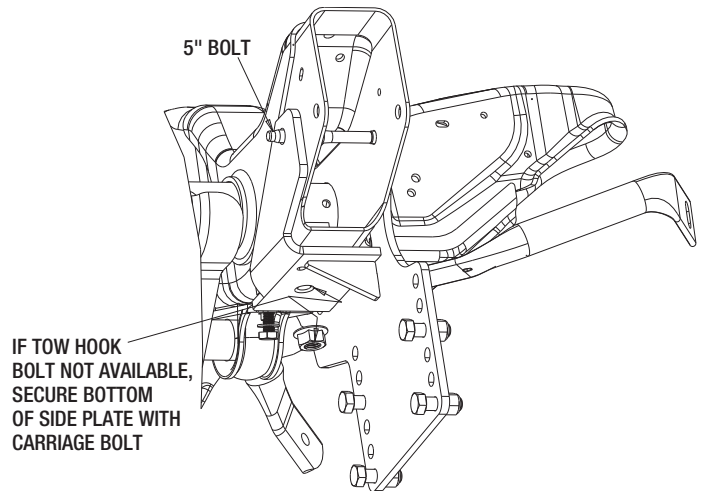

6. Repeat step 3-5 for the PS side plate (2). Notice, the steering box does not exist on PS and must be installed using the bolt on the stick with 1/2" fasteners provided.

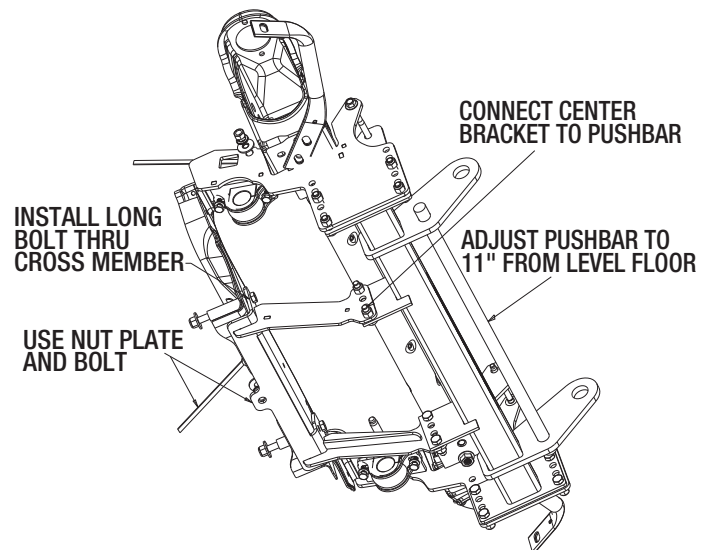

7. Install the pushbar (3) in between the two side plates (1,2) just installed earlier. Use the 1/2" fasteners (11, 7) provided. Adjust the pushbar pin height to be approximately 11" from the level Floor.
8. Connect the Center bracket to the push bar using four 1/2 fasteners provided.
9. Connect the Center bracket to X-member by installing two 5 inch bolts with spacer tubings. At the bottom, secure the bracket with a 1/2" Nut plate (18) and a 1/2" bolt (11).



10. It may be helpful to route the plow and light control harnesses at this point, prior to bumper re-installation.
11. Torque all fasteners as shown in the chart. Check and re-torque all fasteners after 5 hours of usage to ensure safe plow operation. Ensure all coolant lines and wires are clear from moving or hot components.

<b>Recommended Fastener Torque Chart (ft.-lb.)</b>			
Size	 SAE Grade 2	 SAE Grade 5	 SAE Grade 8
1/4-20	6	9	13
5/16-18	11	18	28
3/8-16	19	31	46
3/8-24	24	46	68
7/16-14	30	50	75
1/2-13	45	75	115
9/16-12	66	110	165
5/8-11	93	150	225
3/4-10	150	250	370
7/8-9	150	378	591
1-8	220	583	893

<b>Metric Grade 8.8 (ft.-lb.)</b>			
Size	Torque	Size	Torque
M6	7	M12	60
M8	17	M14	95
M10	35	M16	155

These torque values apply to fasteners except those noted in the instruction.

### WARNING

- DO NOT under any circumstances disable, remove or relocate any sensors or components related to the operation of the air bags.
- Always follow the vehicle manufacturers' recommendations relating to snowplow installation.
- To comply with Federal Regulations and to assure a safe vehicle, the Front Gross Axle Weight Rating (FGAWR), Rear Gross Axle Weight Rating (RGAWR), and the Gross Vehicle Weight Rating (GAWR) must not be exceeded at any time.
- Due to the variety of equipment that can be installed on this vehicle, it is necessary to verify that the Front Gross Axle Weight Rating (FGAWR), Rear Gross Axle Weight Rating (RGAWR), and the Gross Vehicle Weight Rating (GAWR) are not exceeded at any time. This may require weighing the vehicle and adding ballast as necessary. It may also limit payload capacity of the vehicle. It is the operator's responsibility to verify that these ratings are not exceeded.

### CAUTION

- Read all instructions prior to assembly
- It is critical that all fasteners be properly torqued for safe plow operation – see chart above.
- Fasteners should be retorqued after 5-8 hours of plow use

### FULL TWO-YEAR WARRANTY

Manufacturer will repair, or at manufacturer's discretion will replace any part of this snowplow which proves to be defective in workmanship or material under normal use for a period of two years from the date of delivery to the original purchaser. Any cost incurred in returning the product to the supplier is the responsibility of the consumer.

### EXCLUSIONS

Manufacturer shall not be liable for special, incidental, or consequential damages, or for damages resulting from lack of necessary maintenance, from misuse, abuse, acts of God, or alteration of the product. Some states do not allow the exclusion or limitation of incidental or consequential damages, so the above limitation or exclusion may not apply to you.