

MD MOUNT KIT

16062305

CHEVY COLORADO

CANYON '04-'13

(2010-2013 NO Z71)



SnowDogg® Snowplow

TRUCK MOUNT INSTALLATION MANUAL

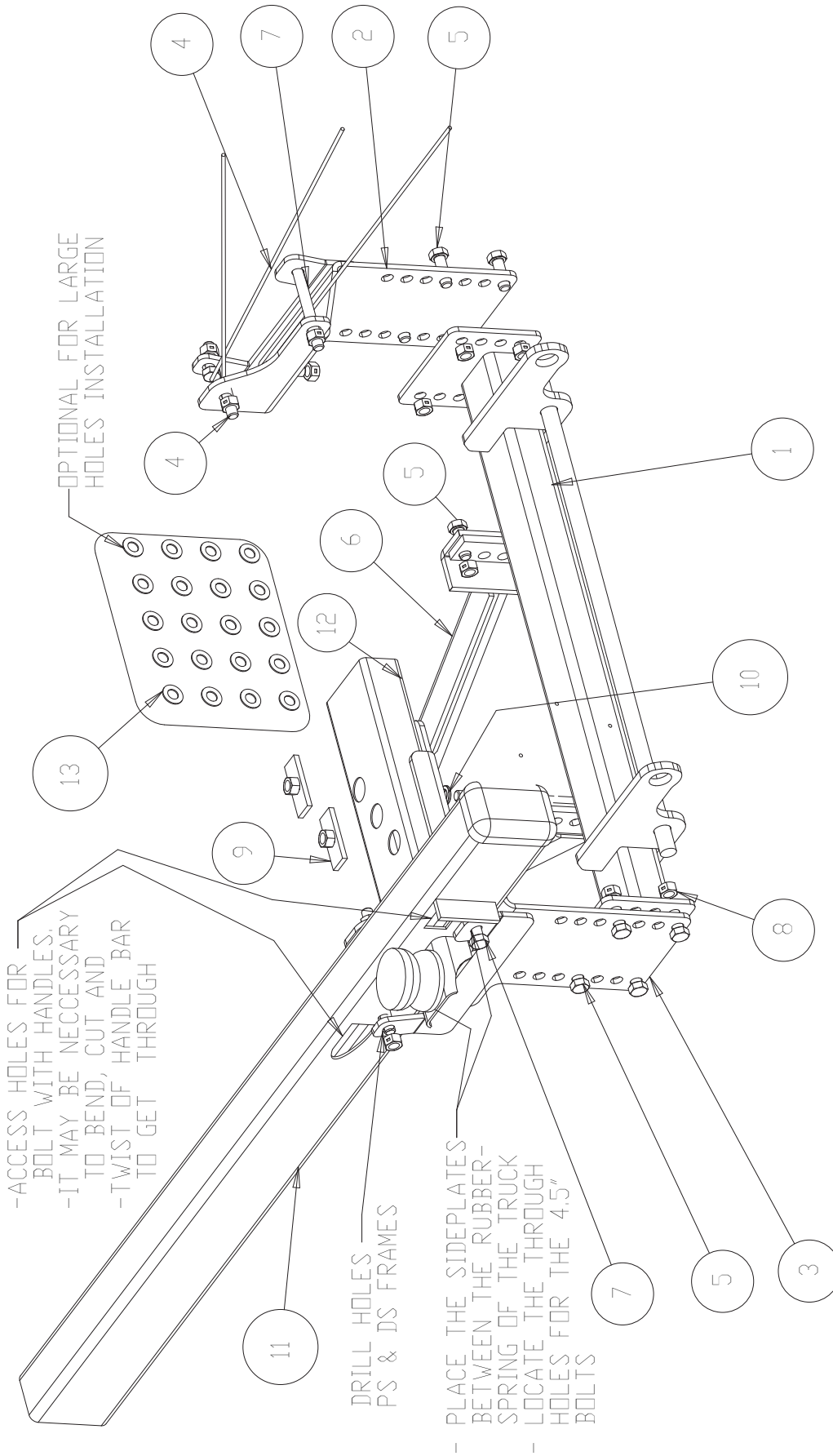

Parts List

ITEM	PART NO.	QTY.	DESCRIPTION
1	16062308	1	Mount, Push Bar, Chevy Colo
2	16062310	1	Bracket, Main Assy Driver Side
3	16062312	1	Bracket, Main Assy Pass Side
4	16801004	6	Screw, Hex HD, 1/2-13 x 4.5 Gr. 5, ZN
5	3006202	14	Screw, Hex HD, 1/2-13 x 1-1/2 Gr. 8 ZC
6	16062314	1	Bracket, Center Support
7	3012583	2	Screw, HHC 1/2-13 x 4.5 Gr. 5 ZN
8	3002397	20	Locknut, Hex 1/2-13, Gr. 8 ZN
9	16062316	2	Plate, Nut-Bolt Assy.
10	-	2	Washer, Heavy Helical Spring Lock, 1/2", Blk.
11	-	1	Beam, Frame
12	-	1	Frame Beam
13	-	20	Washer, Flat, 1/2" SAE, ZN

INSTRUCTIONS

1. Remove the front bumper, bumper fasteners, and skid plate. Set aside for later reinstallation.
2. Hold the PS Main Bracket (3) up against the passenger side frame rail, aligning with the existing through holes between the rubber spring suspension. Secure the bracket through the front hole with one ½-13x4.5" Bolt (7), washer, and nut.

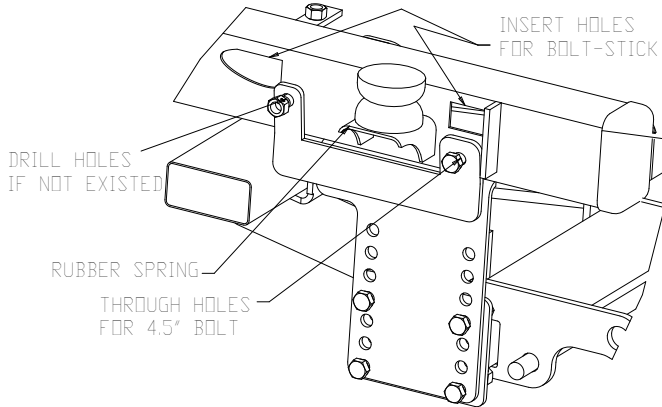

3. Loosely install two ½-13 bolts with Handles. Secure them with two nuts and washers (8,9). Drill the rear hole for the ½" bolts clearance if not already existed. The handles may have to be bended, twisted, and cut off in order to reach the rear.
4. Look to the bottom of the frame, install one ½-13 bolt with handle. Secure it with one nut and washer.

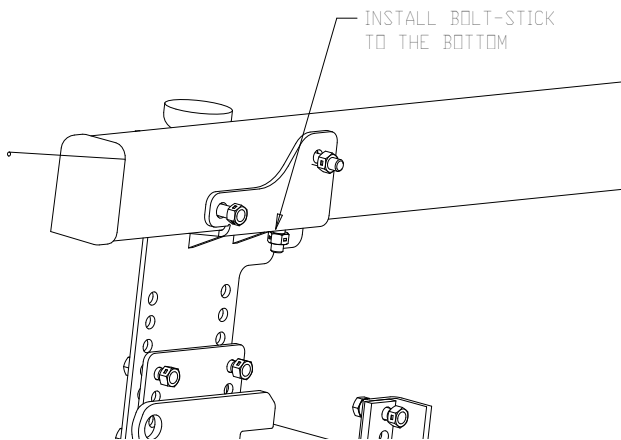

5. Repeat step 2-4 above for Driver side.

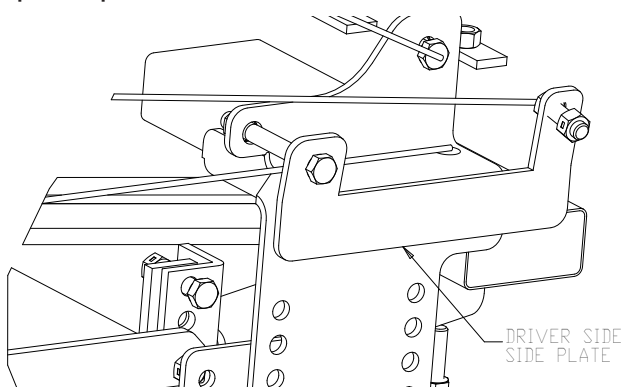

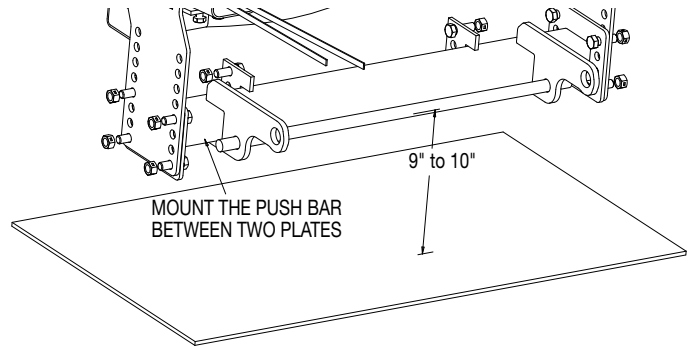

6. Mount the pushbar (1) in place in between the two side-plates using eight ½-13x1.5 bolts and eight nuts (5 & 8). The centerline of the pushbar cross-pin should be approximately 9" to 10" from the ground. Improper mounting height will result in uneven cutting edge wear.

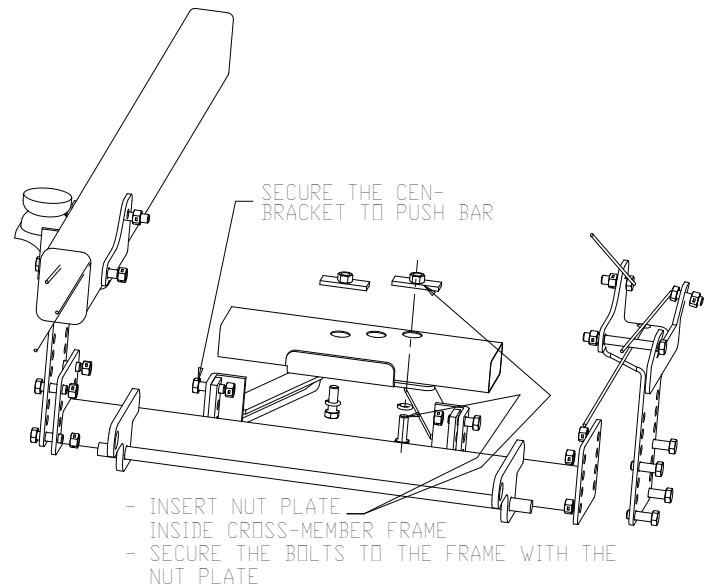

7. Install the Center Support Bracket (6) to the push bar using four bolts and four nuts (5&8). Insert the two nut plates (10) through the nearby hole and secure them with the two ½" bolts and washers (5 & 11).



8. Torque all fasteners as shown in the chart. Check and re-torque all fasteners after 5 hours of usage to ensure safe plow operation.
9. It may be helpful to route the plow and light control harnesses at this point, prior to bumper reinstallation.
10. Reinstall the bumper/air dam assembly and skid plate. The bumper/air dam and skid plate may need to be altered or omitted for reinstallation.

Recommended Fastener Torque Chart (ft.-lb.)			
Size	 SAE Grade 2	 SAE Grade 5	 SAE Grade 8
1/4-20	6	9	13
5/16-18	11	18	28
3/8-16	19	31	46
3/8-24	24	46	68
7/16-14	30	50	75
1/2-13	45	75	115
9/16-12	66	110	165
5/8-11	93	150	225
3/4-10	150	250	370
7/8-9	150	378	591
1-8	220	583	893

Metric Grade 8.8 (ft.-lb.)			
Size	Torque	Size	Torque
M6	7	M12	60
M8	17	M14	95
M10	35	M16	155

These torque values apply to fasteners except those noted in the instruction.

WARNING

- DO NOT under any circumstances disable, remove or relocate any sensors or components related to the operation of the air bags.
- Always follow the vehicle manufacturers' recommendations relating to snowplow installation.
- To comply with Federal Regulations and to assure a safe vehicle, the Front Gross Axle Weight Rating (FGAWR), Rear Gross Axle Weight Rating (RGAWR), and the Gross Vehicle Weight Rating (GAWR) must not be exceeded at any time.
- Due to the variety of equipment that can be installed on this vehicle, it is necessary to verify that the Front Gross Axle Weight Rating (FGAWR), Rear Gross Axle Weight Rating (RGAWR), and the Gross Vehicle Weight Rating (GAWR) are not exceeded at any time. This may require weighing the vehicle and adding ballast as necessary. It may also limit payload capacity of the vehicle. It is the operator's responsibility to verify that these ratings are not exceeded.

CAUTION

- Read all instructions prior to assembly
- It is critical that all fasteners be properly torqued for safe plow operation – see chart above.
- Fasteners should be retorqued after 5-8 hours of plow use

FULL TWO-YEAR WARRANTY

Manufacturer will repair, or at manufacturer's discretion will replace any part of this snowplow which proves to be defective in workmanship or material under normal use for a period of one year from the date of delivery to the original purchaser. Any cost incurred in returning the product to the supplier is the responsibility of the consumer.

EXCLUSIONS

Manufacturer shall not be liable for special, incidental, or consequential damages, or for damages resulting from lack of necessary maintenance, from misuse, abuse, acts of God, or alteration of the product. Some states do not allow the exclusion or limitation of incidental or consequential damages, so the above limitation or exclusion may not apply to you.