

# EX/TE/VX/CM MOUNT KIT 16062420

GM 45/5500, 2019+ STD  
(FOR 23" LOWER-BUMPER MOUNTING BOLT HEIGHT)



# SnowDogg® Snowplow

## TRUCK MOUNT INSTALLATION MANUAL

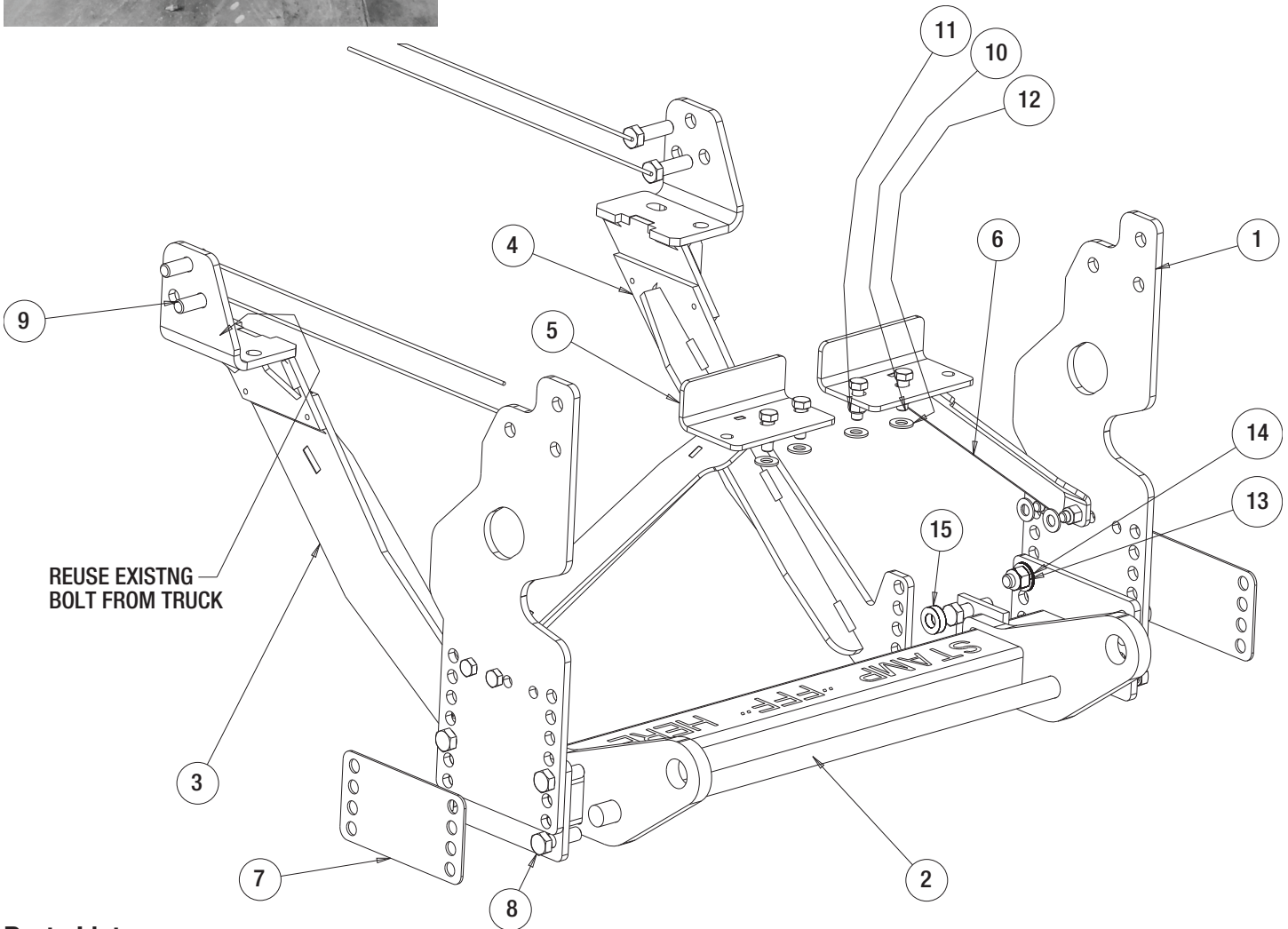
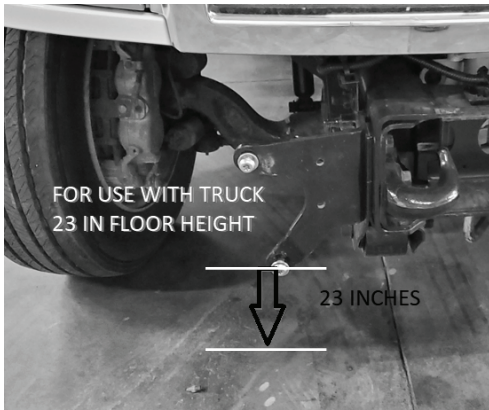

**Parts List**

ITEM	PART NO.	QTY.	DESCRIPTION
1	3039541	2	SIDEPLATE, GM 4500 19+
2	16061031	1	PUSHBAR, F650 CM
3	16062421	1	REAR BRACE, PS, 4500 GM
4	16062422	1	REAR BRACE, DS, 4500 GM
5	16062423	1	ARM, SHORT SUPPORT, PS
6	16062424	1	ARM, SHORT SUPPORT, DS
7	3040394	2	PLATE, PUSH MOUNT, THICKNESS SPACER
8	FCS063011200	12	SCREW, HEX CAP 5/8-11 X 2 GR5 ZN

ITEM	PART NO.	QTY.	DESCRIPTION
9	16801006	4	SCREW, HEX HD, 5/8-11x2 GR 5 W/HDL
10	3006202	8	SCREW, HEX HD - 1/2-13 X 1-1/2 GR 8 ZC
11	3002397	8	LOCKNUT, HEX NYLOCK, 1/2-13 ZN, G8
12	FWF050106010	8	WASHER, FLAT, 1/2 X 1.062 X .095, ZN
13	FNE063011069	16	NUT, NYLOCK 5/8-11, ZN
14	3011228	16	WASHER, 5/8 SAE FLAT ZN
15	3047246	8	WASHER, 5/8 BOLT X 3/8 THICK

## INSTRUCTIONS

1. Remove the bumper and bumper fasteners. Set aside for later reinstallation.
2. Hold the PS Sideplate (1) up against the PS frame of the truck, aligning it to the three existing holes from the truck frame. Re-use existing bolts from these three holes.

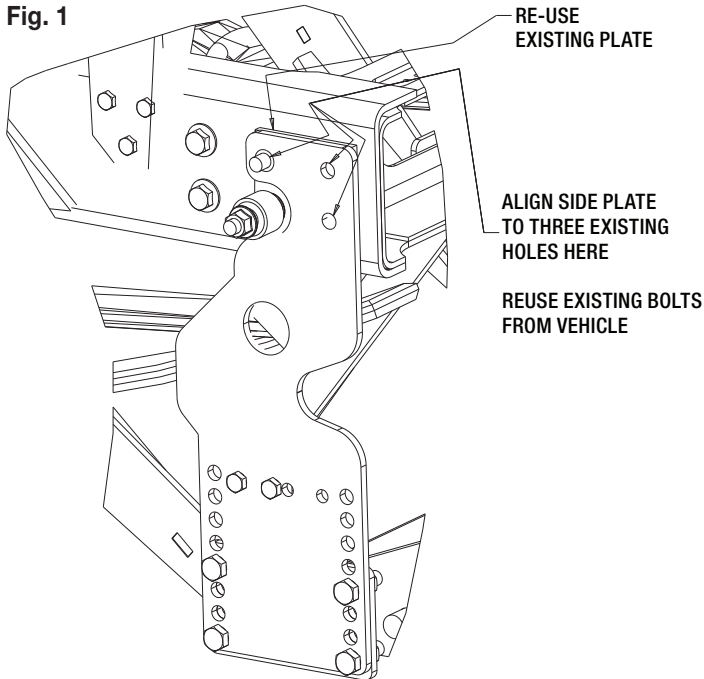

3. Repeat step number 2 for DS Sideplate (1).
4. Install the Pushbar (2) between the two Sideplates using eight 5/8" screws (8) and eight flange nuts (13). A 1/8" spacer (7) is needed in between the Pushbar and Side Plate. The center line of the push bar Cross Pin should be approximately 11" from the level ground. It may be necessary to notch the bumper to clear room for the pushbar height adjustment.

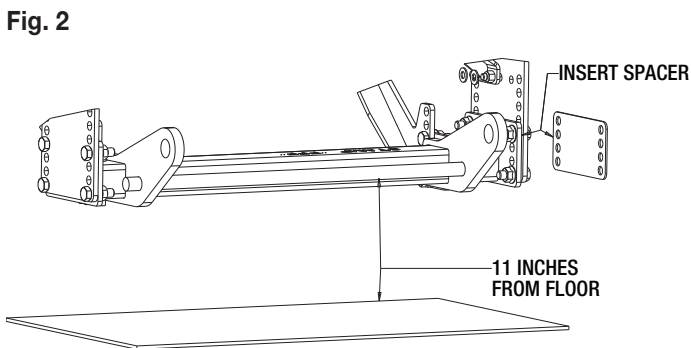

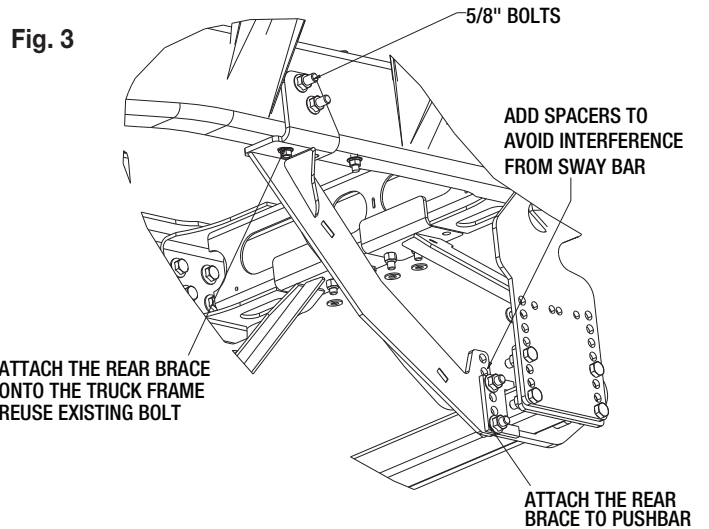

5. Install the PS Rear Brace (3) onto the Pushbar (1) using two 5/8" bolts and nuts. Secure the back of the bracket onto the back part of the Frame aligning to the bottom metric bolts. Reuse the existing nuts to secure it to the frame. Attach two more 5/8" bolts to the frame of the truck using the existing holes of the truck. For some early models, it is necessary to drill the two holes here. Secure them with two 5/8" nuts.

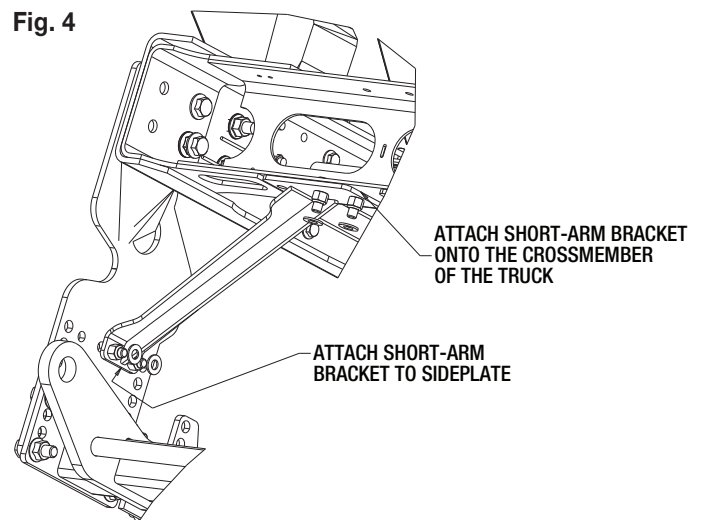

6. Repeat for DS Rear Brace bracket (4).
7. Install the PS Short Arm (5) onto the Side Plate (1) using two 1/2" bolts, nuts and washers. Attach the opposite end to the Cross member of the truck using a pair of 1/2" bolts, nuts, and washers.



8. Repeat for the DS Short Arm bracket (6).
9. Torque all fasteners as shown in the chart. Check and re-torque all fasteners after 5 hours of usage to ensure safe plow operation. Ensure all coolant lines and wires are clear from moving or hot components.

<b>Recommended Fastener Torque Chart (ft.-lb.)</b>			
Size	 SAE Grade 2	 SAE Grade 5	 SAE Grade 8
1/4-20	6	9	13
5/16-18	11	18	28
3/8-16	19	31	46
3/8-24	24	46	68
7/16-14	30	50	75
1/2-13	45	75	115
9/16-12	66	110	165
5/8-11	93	150	225
3/4-10	150	250	370
7/8-9	150	378	591
1-8	220	583	893

<b>Metric Grade 8.8 (ft.-lb.)</b>			
Size	Torque	Size	Torque
M6	7	M12	60
M8	17	M14	95
M10	35	M16	155

These torque values apply to fasteners except those noted in the instruction.

**WARNING**

- DO NOT under any circumstances disable, remove or relocate any sensors or components related to the operation of the air bags.
- Always follow the vehicle manufacturers' recommendations relating to snowplow installation.
- To comply with Federal Regulations and to assure a safe vehicle, the Front Gross Axle Weight Rating (FGAWR), Rear Gross Axle Weight Rating (RGAWR), and the Gross Vehicle Weight Rating (GAWR) must not be exceeded at any time.
- Due to the variety of equipment that can be installed on this vehicle, it is necessary to verify that the Front Gross Axle Weight Rating (FGAWR), Rear Gross Axle Weight Rating (RGAWR), and the Gross Vehicle Weight Rating (GAWR) are not exceeded at any time. This may require weighing the vehicle and adding ballast as necessary. It may also limit payload capacity of the vehicle. It is the operator's responsibility to verify that these ratings are not exceeded.

**CAUTION**

- Read all instructions prior to assembly
- It is critical that all fasteners be properly torqued for safe plow operation – see chart above.
- Fasteners should be retorqued after 5-8 hours of plow use

**FULL TWO-YEAR WARRANTY**

Manufacturer will repair, or at manufacturer's discretion will replace any part of this snowplow which proves to be defective in workmanship or material under normal use for a period of two year from the date of delivery to the original purchaser. Any cost incurred in returning the product to the supplier is the responsibility of the consumer.

**EXCLUSIONS**

Manufacturer shall not be liable for special, incidental, or consequential damages, or for damages resulting from lack of necessary maintenance, from misuse, abuse, acts of God, or alteration of the product. Some states do not allow the exclusion or limitation of incidental or consequential damages, so the above limitation or exclusion may not apply to you.