

HD/EX MOUNT KIT

16061110

FORD '09-'10 F150

FORD '13-'14 F150



SnowDogg® Snowplow

TRUCK MOUNT INSTALLATION MANUAL

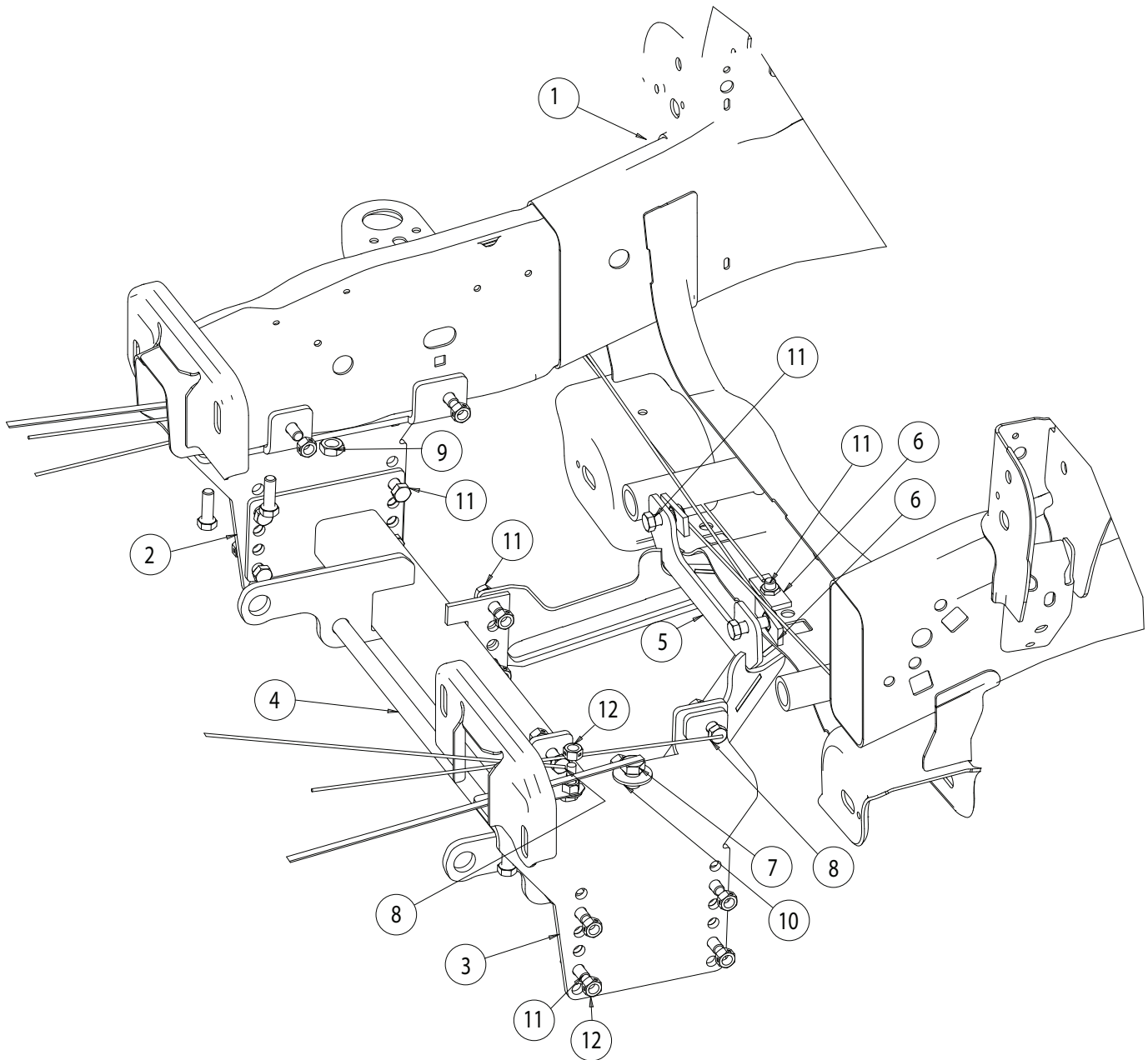

Parts List

ITEM	PART NO.	QTY.	DESCRIPTION
1		1	F150 Frame
2	16061117	1	Mount, PS Side, Ford F150 2009+
3	16061116	1	Mount, DS Side, Ford F150 2009+
4	16061122A	1	Pushbar, Ford F150 HD
5	16061118	1	Bracket, Center Support F150 2009+
6	16061121	3	Nut Plate, w/HDL Weldment
7	16801006	2	Screw, Hex HD, 5/8-11 x 2 Gr. 5 w/HDL
8	16801004	4	Screw, Hex HD, 1/2-13 x 1-1/2 Gr. 5, w/HDL
9	FNE063011069S	2	Nut, Hex Jam, Center Lock 5/8-11 ZN
10	3000144	2	Washer, FL - 5/8 USS ZN
11	3006202	19	Screw, Hex HD - 1/2-13 x 1-1/2 Gr.8 ZN
12	3002397	20	Locknut, Hex 1/2-13 Gr. 8 ZN

INSTRUCTIONS

1. Remove the Passenger Side Tow Hook Bolts and set aside.
2. Insert one 5/8-11 Bolt with Handle (7) and one 5/8" Flat Washer (10) into the rear slot in the PS truck frame. Place the PS Side Plate (2) against the frame, aligning with the 5/8-11 Bolt (7). Secure it with a 5/8 Lock Nut (12). (see fig.1 for step 1-5)

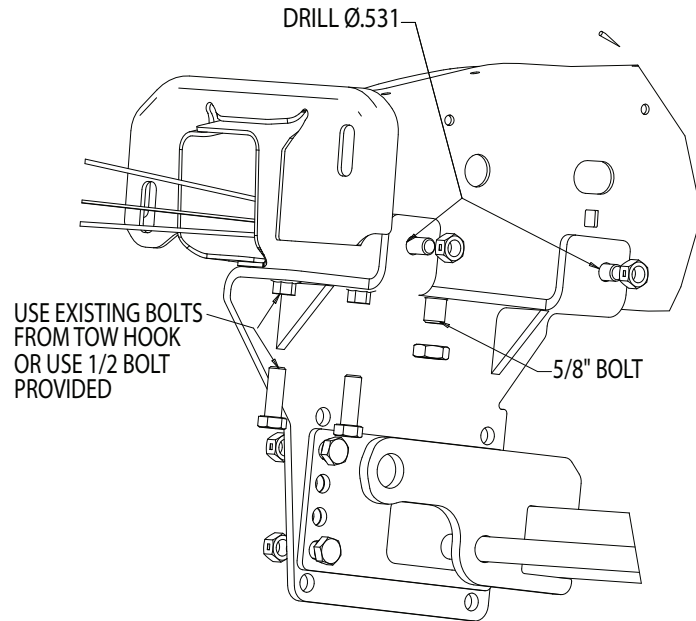

3. Install two existing bolts through the existing holes in the bottom of the frame (optionally use the 1/2" Bolts and Nuts provided).
4. Using the PS Side Plate as a template, drill two Ø.531 holes through the side of the frame.
5. Install two 1/2-13 Bolt With Handles (8) through these drilled holes and secure them with two 1/2-13 Hex Nuts (12).
6. Repeat Step 1-5 for the DS Side Plate (3).

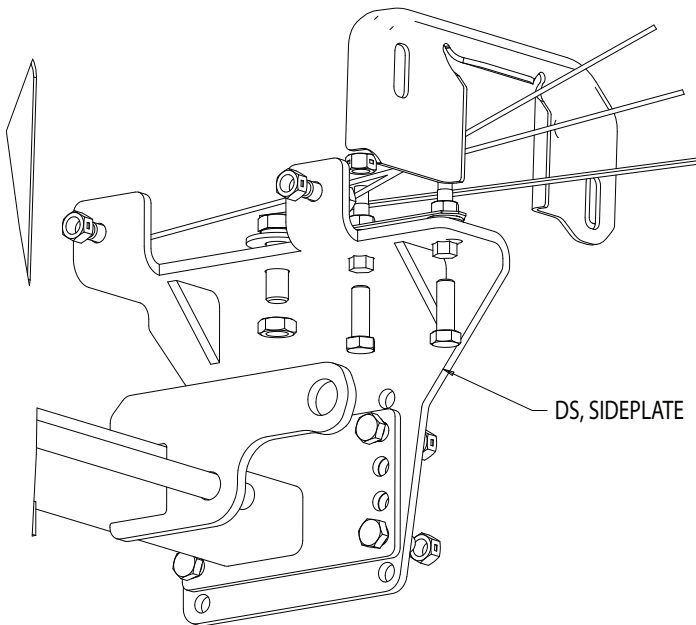

7. Mount the Pushbar (4) in Place between the PS and DS Side Plates using the eight 1/2-13 Bolts (11) and eight Lock Nuts (12). The Centerline of the Pushbar Cross Pin should be approximately 11" from the ground. The air dam of the vehicle may need to be altered to accommodate this height. Improper mounting height will result in uneven cutting edge wear.

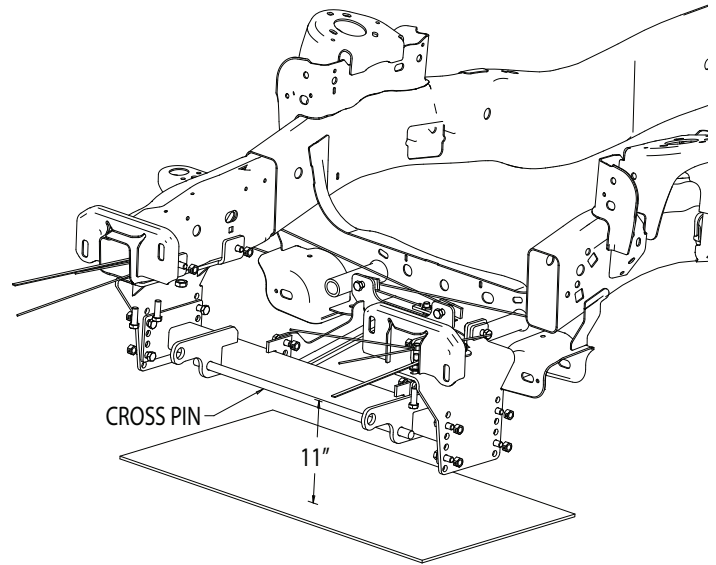

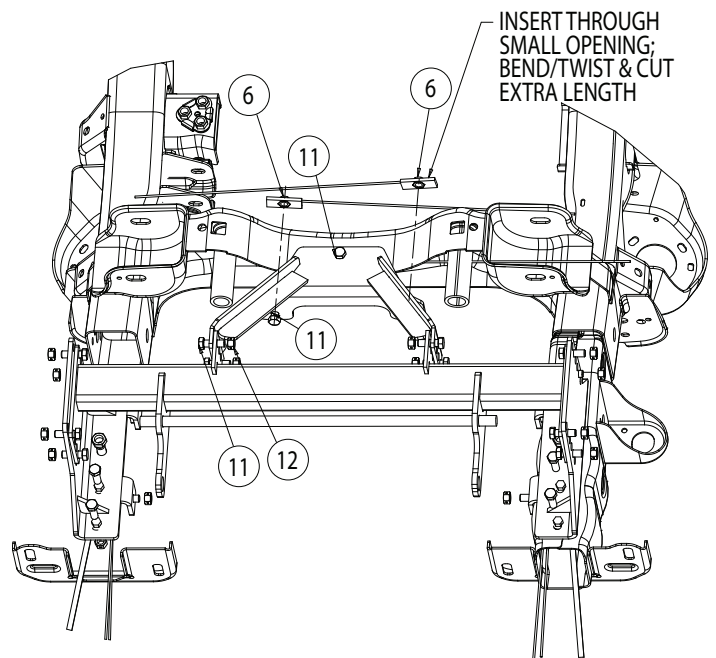

8. Position the Center Support Bracket (5) onto to Pushbar (4) and secure it with four 1/2" Bolts (11) and Locknuts (12). See fig. 4
9. Secure the Center Support Bracket (5) to the frame of the truck using three Nut Plate w/ Handle (6) and three 1/2" Bolts (11). See fig.4 below.

BOTTOM VIEW OF THE TRUCK LOOKING UP



10. Torque all fasteners as shown in the chart. Check and re-torque all fasteners after 5 hours of usage to ensure safe plow operation. Ensure all coolant lines and wires are clear of moving or hot components and secure as necessary.

Recommended Fastener Torque Chart (ft.-lb.)			
Size	 SAE Grade 2	 SAE Grade 5	 SAE Grade 8
1/4-20	6	9	13
5/16-18	11	18	28
3/8-16	19	31	46
3/8-24	24	46	68
7/16-14	30	50	75
1/2-13	45	75	115
9/16-12	66	110	165
5/8-11	93	150	225
3/4-10	150	250	370
7/8-9	150	378	591
1-8	220	583	893

Metric Grade 8.8 (ft.-lb.)			
Size	Torque	Size	Torque
M6	7	M12	60
M8	17	M14	95
M10	35	M16	155

These torque values apply to fasteners except those noted in the instruction.

WARNING

- DO NOT under any circumstances disable, remove or relocate any sensors or components related to the operation of the air bags.
- Always follow the vehicle manufacturers' recommendations relating to snowplow installation.
- To comply with Federal Regulations and to assure a safe vehicle, the Front Gross Axle Weight Rating (FGAWR), Rear Gross Axle Weight Rating (RGAWR), and the Gross Vehicle Weight Rating (GAWR) must not be exceeded at any time.
- Due to the variety of equipment that can be installed on this vehicle, it is necessary to verify that the Front Gross Axle Weight Rating (FGAWR), Rear Gross Axle Weight Rating (RGAWR), and the Gross Vehicle Weight Rating (GAWR) are not exceeded at any time. This may require weighing the vehicle and adding ballast as necessary. It may also limit payload capacity of the vehicle. It is the operator's responsibility to verify that these ratings are not exceeded.

CAUTION

- Read all instructions prior to assembly
- It is critical that all fasteners be properly torqued for safe plow operation – see chart above.
- Fasteners should be retorqued after 5-8 hours of plow use

FULL TWO-YEAR WARRANTY

Manufacturer will repair, or at manufacturer's discretion will replace any part of this snowplow which proves to be defective in workmanship or material under normal use for a period of two years from the date of delivery to the original purchaser. Any cost incurred in returning the product to the supplier is the responsibility of the consumer.

EXCLUSIONS

Manufacturer shall not be liable for special, incidental, or consequential damages, or for damages resulting from lack of necessary maintenance, from misuse, abuse, acts of God, or alteration of the product. Some states do not allow the exclusion or limitation of incidental or consequential damages, so the above limitation or exclusion may not apply to you.