

MD MOUNT KIT

16062115A

GM 1500, 2007 - 2013



SnowDogg® Snowplow

TRUCK MOUNT INSTALLATION MANUAL

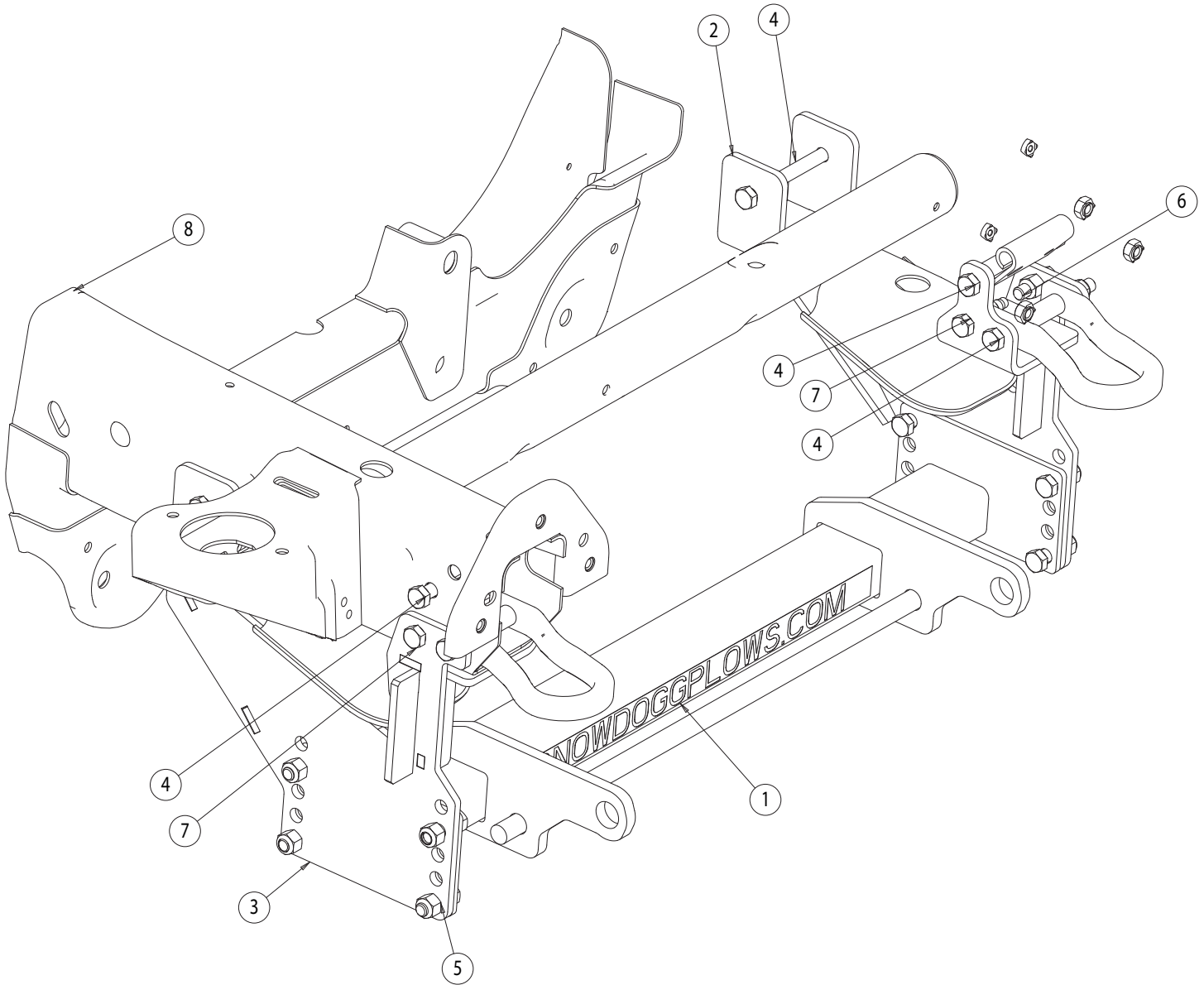

Parts List

ITEM	PART NO.	QTY.	DESCRIPTION
1	16062123	1	MD Pushbar, GM 1500
2	16062121	1	Side Plate, DS
3	16062122	1	Side Plate, PS
4	FCS050013550	6	Screw, HHC-1/2-13 x 5 1/2, ZN Gr. 5
5	3002397	16	Locknut, Hex Nylock 1/2-13, ZN Gr. 8
6	3006202	10	Screw, Hex HD, 1/2-13 x 1-1/2, ZN Gr. 8
7	3006202X	2	Existing Bolt From The Truck
8	-	1	GM Truck Frame

INSTRUCTIONS

1. Remove plastic air dam from bumper and remove front bumper (For 2014, it is necessary to remove the radiator grille and miscellaneous fasteners to gain access to the bumper bolts).
2. Remove the existing tow hook bolts. Keep the tow hooks in place.
3. Hold the **PS SIDE MOUNT PLATE** (3) against the frame, aligning with the existing tow hook holes.

DRILL THROUGH BOTH WALLS FOR 1/2 INCH BOLT

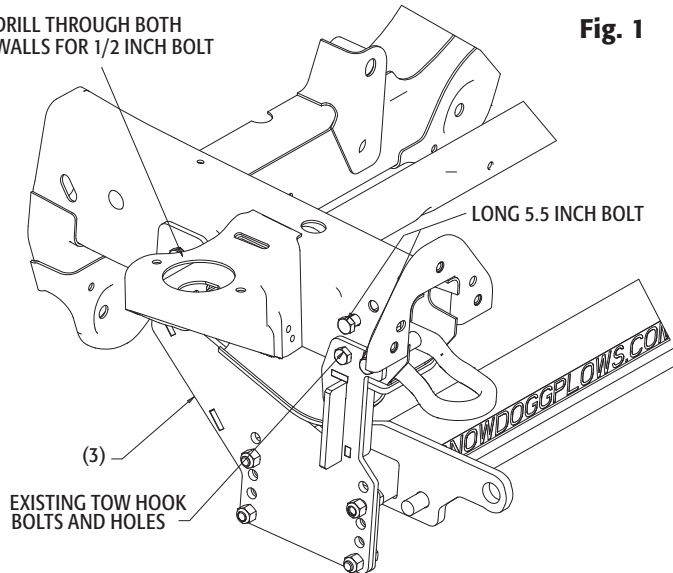

Fig. 1

4. Keep the tow hook in place, loosely install two 1/2"-13x5" **HEX HEAD BOLTS** (4) horizontally through the frame. The lower bolt will pass through the front hole of the tow hook.
5. The top bolt position may require drilling to $\varnothing.531$. Reinstall the existing rear tow hook bolts.
6. Using the **MOUNT PLATE** (3) as a template, drill $\varnothing.531$ hole as shown in the Fig 2. Install one 1/2"-13x1-1/2" **HEX HEAD BOLT** (6) and one 1/2"-13 **LOCK NUT**.

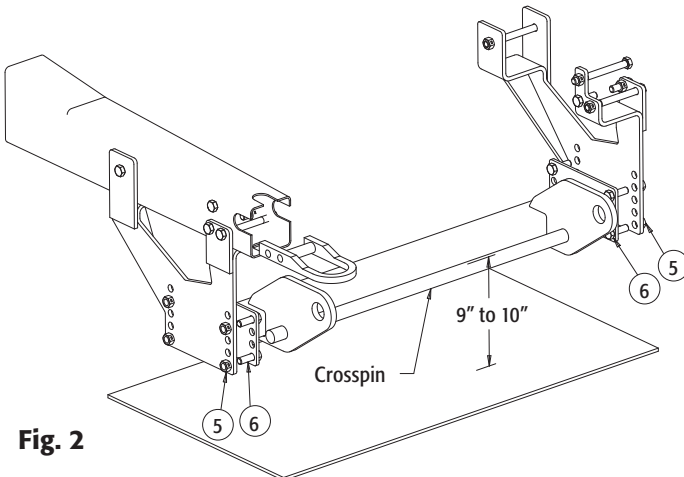
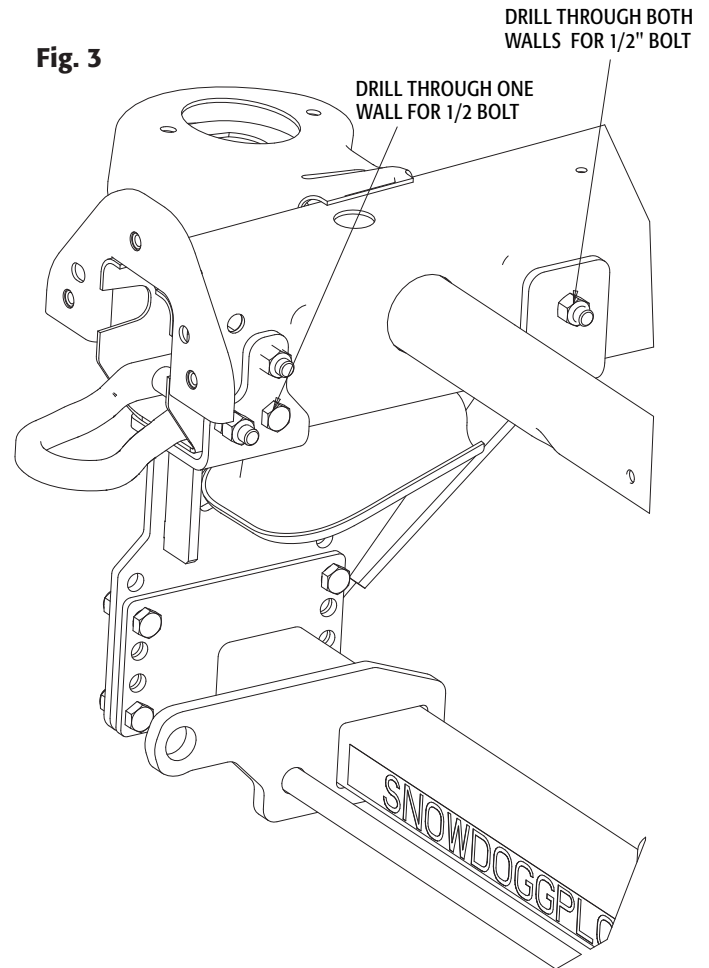





Fig. 2

Fig. 3



7. Using the **MOUNT PLATE** (3) as a template, drill $\varnothing.531$ hole for the rear bracket thru both walls of the frame as shown in the Fig 1 and Fig 2.
8. Install one 1/2"-13x5" **HEX HEAD BOLT** (4) and one 1/2"-13 **LOCK NUT** (5). Do not over-tighten – do not deform the frame.
9. Repeat steps 3-8 for the DS Side Mount Plate (2).
10. Mount the **PUSHBAR** (1) in place between the two side plates using eight 1/2"-13x1-1/2" **HEX HEAD BOLTS** (6) and eight 1/2"-13 lock nuts (5). The centerline of the Pushbar Crosspin should be approximately 9" to 10" from the ground. The air dam of the vehicle may need to be altered to accommodate this height. Improper mounting height will result in uneven cutting edge wear.
11. Torque all fasteners as shown in the chart. Check and re-torque all fasteners after 5 hours of usage to ensure safe plow operation. Ensure all coolant lines and wires are clear of moving or hot components and tie up as necessary.

Recommended Fastener Torque Chart (ft.-lb.)			
Size	 SAE Grade 2	 SAE Grade 5	 SAE Grade 8
1/4-20	6	9	13
5/16-18	11	18	28
3/8-16	19	31	46
3/8-24	24	46	68
7/16-14	30	50	75
1/2-13	45	75	115
9/16-12	66	110	165
5/8-11	93	150	225
3/4-10	150	250	370
7/8-9	150	378	591
1-8	220	583	893
Metric Grade 8.8 (ft.-lb.)			
Size	Torque	Size	Torque
M6	7	M12	60
M8	17	M14	95
M10	35	M16	155
These torque values apply to fasteners except those noted in the instruction.			

WARNING

- DO NOT under any circumstances disable, remove or relocate any sensors or components related to the operation of the air bags.
- Always follow the vehicle manufacturers' recommendations relating to snowplow installation.
- To comply with Federal Regulations and to assure a safe vehicle, the Front Gross Axle Weight Rating (FGAWR), Rear Gross Axle Weight Rating (RGAWR), and the Gross Vehicle Weight Rating (GAWR) must not be exceeded at any time.
- Due to the variety of equipment that can be installed on this vehicle, it is necessary to verify that the Front Gross Axle Weight Rating (FGAWR), Rear Gross Axle Weight Rating (RGAWR), and the Gross Vehicle Weight Rating (GAWR) are not exceeded at any time. This may require weighing the vehicle and adding ballast as necessary. It may also limit payload capacity of the vehicle. It is the operator's responsibility to verify that these ratings are not exceeded.

CAUTION

- Read all instructions prior to assembly
- It is critical that all fasteners be properly torqued for safe plow operation – see chart above.
- Fasteners should be retorqued after 5-8 hours of plow use

FULL TWO-YEAR WARRANTY

Manufacturer will repair, or at manufacturer's discretion will replace any part of this snowplow which proves to be defective in workmanship or material under normal use for a period of one year from the date of delivery to the original purchaser. Any cost incurred in returning the product to the supplier is the responsibility of the consumer.

EXCLUSIONS

Manufacturer shall not be liable for special, incidental, or consequential damages, or for damages resulting from lack of necessary maintenance, from misuse, abuse, acts of God, or alteration of the product. Some states do not allow the exclusion or limitation of incidental or consequential damages, so the above limitation or exclusion may not apply to you.