

MD MOUNT KIT

16062285

DODGE RAM 2013 - 2018 2500/3500



SnowDogg® Snowplow

TRUCK MOUNT INSTALLATION MANUAL

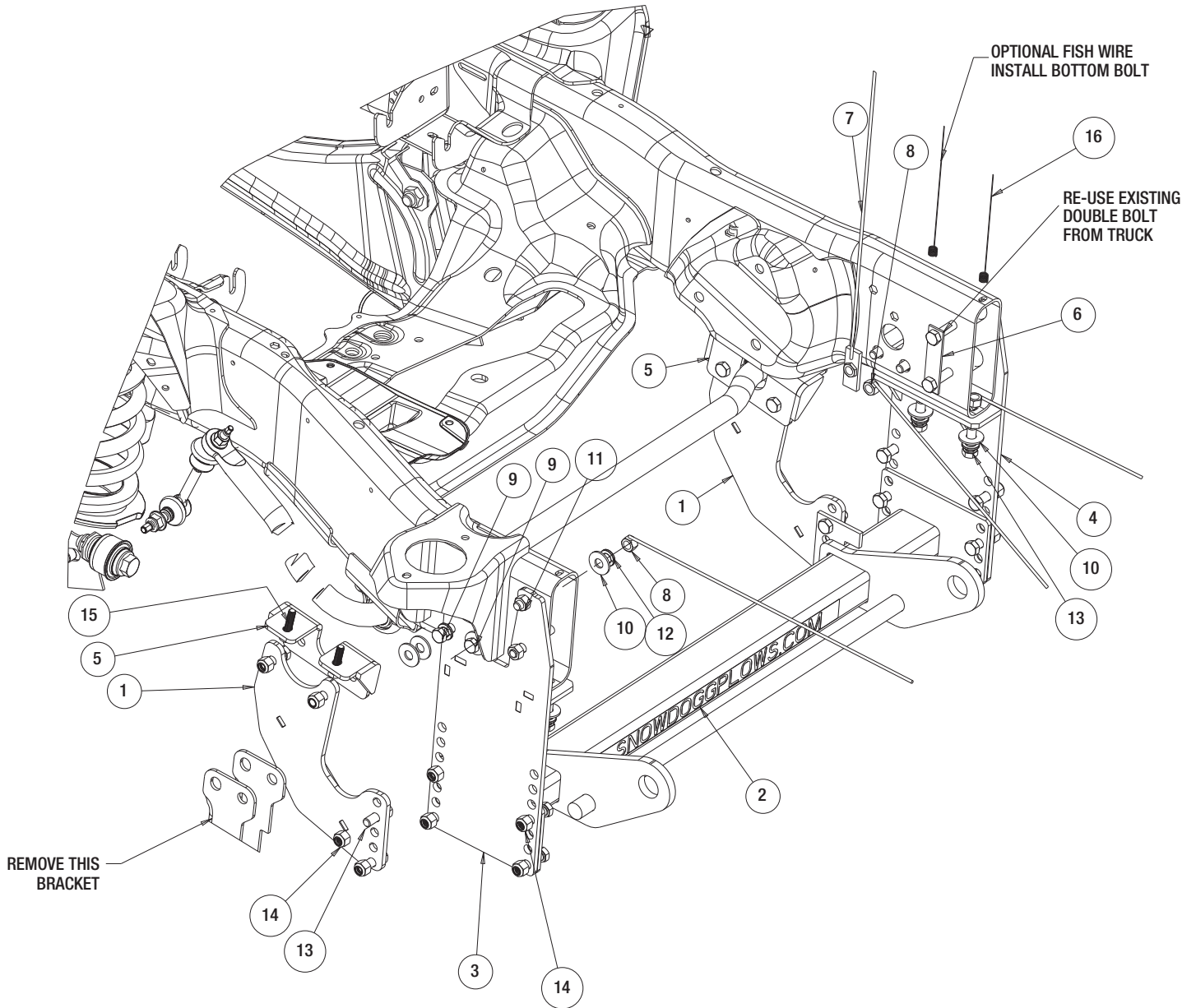

Bill of Materials

ITEM	PART NO.	QTY.	DESCRIPTION
1	16062278	2	REAR BRACE, ARM
2	16062281	1	PUSHBAR, RAM 13+, W/ MID TAB, HD
3	16062271	1	SIDEPLATE, PS RAM 13-14
4	16062272	1	SIDEPLATE, DS RAM 13-14
5	16062277	2	BRACKET, SWAYBAR ATTACH
6	-	2	EXISTING DOUBLE BOLT FROM TRUCK
7	16061121	2	NUT-PLATE, W/ HANDLE WELDMENT
8	3011523	6	NUT, HEX, 1/2-13 W/HANDLE, GR 8
9	3005140	4	SCREW, HH1/2-13 x 3.5, GR 5 ZN

ITEM	PART NO.	QTY.	DESCRIPTION
10	FWF050138014	12	WASHER, FLAT, 1/2" USS, ZN
11	-	2	NUT, 1/2-13 HEX GR. 8 ZP
12	FWL050088013	8	WASHER, LOCK - 1/2 SPLIT ZN
13	3006202	20	SCREW, HEX HD - 1/2-13 X 1-1/2 GR 8 ZC
14	3002397	16	LOCKNUT, HEX NYLOCK, 1/2-13 ZN, G8
15	3035677	4	SCREW, M10 X 1.5MM X 45MM, ZN 10.9
16	3002169	2	WIRE, FISH
17	16801004	2	1/2" BOLT STICK, SPARE
18	3038493	2	SWAYBAR SPACER

INSTRUCTIONS

1. It is recommended to remove the bumper temporarily for this project.
2. Remove the tow hooks, they will not be used.

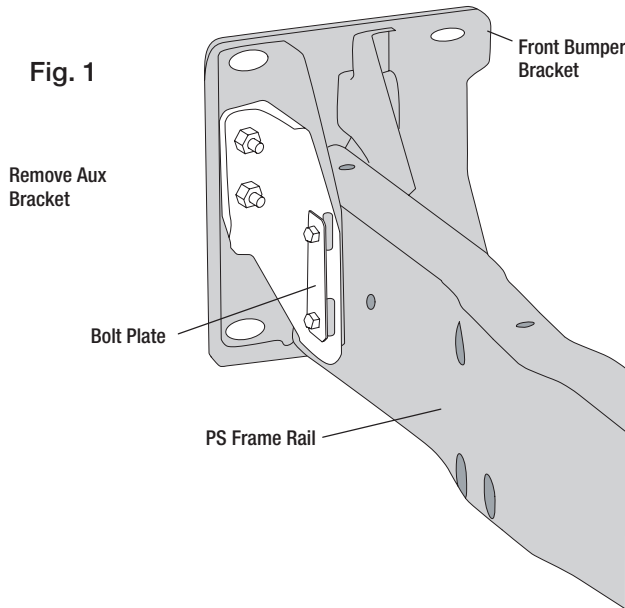

3. Remove the nuts from the PS Bolt Plate. Install the PS Side Plate onto the double bolts. Reinstall the two nuts just removed earlier. Install the long bolts (PN 3005140) provided in the lower holes. Secure these with the 1/2 fasteners provided. Diesel vehicle may require thin spacers nut to avoid interference (see Fig. 2).

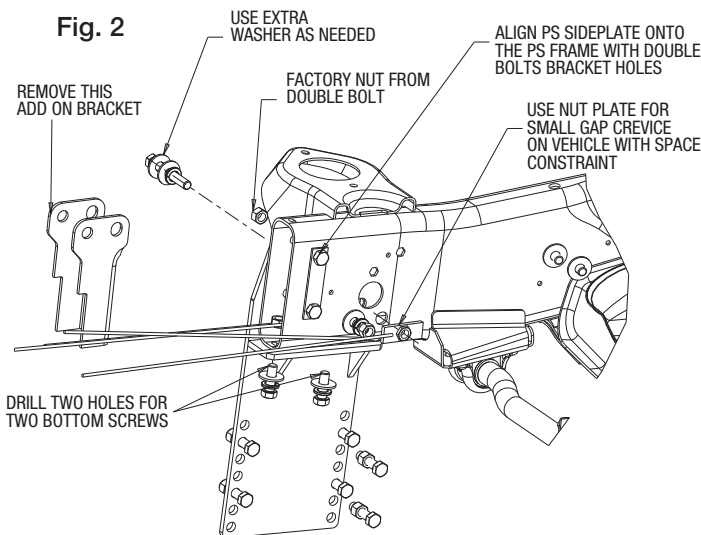

4. Look to the bottom of Fig 2, drill out two 1/2 inch holes to allow the 1/2 bolt installation from the bottom. Secure it with the nut on a stick and some washers. The stick may have to be bent and twisted in order to match the holes you just drilled.
5. Repeat step number 3-4 for Driver Side Plate installation (see Fig.3).

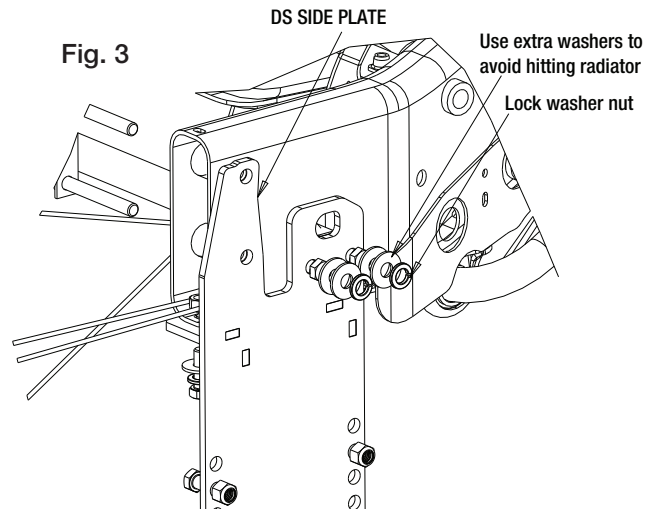

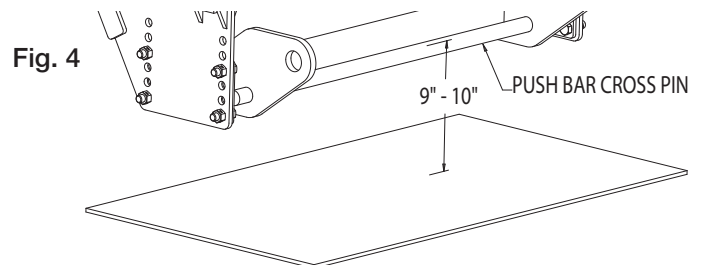

6. Assemble the Pushbar between two Side Plates using eight 1.5" bolts provided. Adjust the push Bar up and down. The center line of the push bar Cross Pin should be approximately 9" to 10" from the level ground. The plastic extension from the bumper/air deflector may need to be removed or modified.

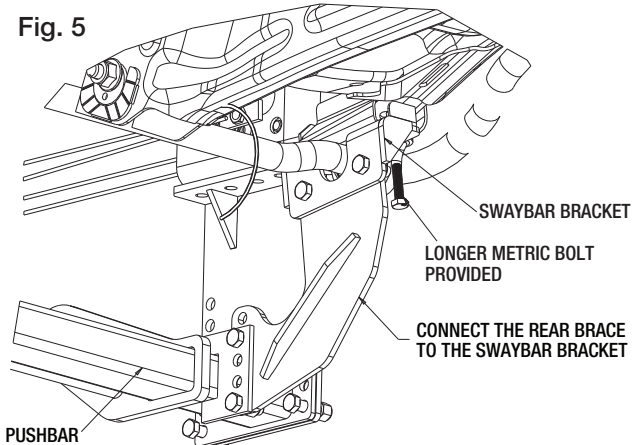

7. Lower the swaybar from the bottom of the truck temporarily. Install the Swaybar Bracket (5) and re-attach the swaybar into place like a sandwich. Make sure to insert the Swaybar Spacer (18) up against the rubber toward the frame. Secure it with two new metric bolts (15). Connect the Rear Brace (1) to the Pushbar (2) and the Swaybar Bracket (5). Loosely, secure them together with four 1/2" fasteners. (see Fig 5)



8. Repeat for the DS Rear Arm Bracket.
9. Torque all fasteners as shown in the chart. Check and re-torque all fasteners after 5 hours of usage to ensure safe plow operation. Ensure all coolant lines and wires are clear from moving or hot components.

Recommended Fastener Torque Chart (ft.-lb.)			
Size	 SAE Grade 2	 SAE Grade 5	 SAE Grade 8
1/4-20	6	9	13
5/16-18	11	18	28
3/8-16	19	31	46
3/8-24	24	46	68
7/16-14	30	50	75
1/2-13	45	75	115
9/16-12	66	110	165
5/8-11	93	150	225
3/4-10	150	250	370
7/8-9	150	378	591
1-8	220	583	893

Metric Grade 8.8 (ft.-lb.)			
Size	Torque	Size	Torque
M6	7	M12	60
M8	17	M14	95
M10	35	M16	155

These torque values apply to fasteners except those noted in the instruction.

WARNING

- DO NOT under any circumstances disable, remove or relocate any sensors or components related to the operation of the air bags.
- Always follow the vehicle manufacturers' recommendations relating to snowplow installation.
- To comply with Federal Regulations and to assure a safe vehicle, the Front Gross Axle Weight Rating (FGAWR), Rear Gross Axle Weight Rating (RGAWR), and the Gross Vehicle Weight Rating (GAWR) must not be exceeded at any time.
- Due to the variety of equipment that can be installed on this vehicle, it is necessary to verify that the Front Gross Axle Weight Rating (FGAWR), Rear Gross Axle Weight Rating (RGAWR), and the Gross Vehicle Weight Rating (GAWR) are not exceeded at any time. This may require weighing the vehicle and adding ballast as necessary. It may also limit payload capacity of the vehicle. It is the operator's responsibility to verify that these ratings are not exceeded.

CAUTION

- Read all instructions prior to assembly
- It is critical that all fasteners be properly torqued for safe plow operation – see chart above.
- Fasteners should be retorqued after 5-8 hours of plow use

FULL TWO-YEAR WARRANTY

Manufacturer will repair, or at manufacturer's discretion will replace any part of this snowplow which proves to be defective in workmanship or material under normal use for a period of one year from the date of delivery to the original purchaser. Any cost incurred in returning the product to the supplier is the responsibility of the consumer.

EXCLUSIONS

Manufacturer shall not be liable for special, incidental, or consequential damages, or for damages resulting from lack of necessary maintenance, from misuse, abuse, acts of God, or alteration of the product. Some states do not allow the exclusion or limitation of incidental or consequential damages, so the above limitation or exclusion may not apply to you.