

MD MOUNT KIT

16063145

DODGE RAM 1500 2009-2018



SnowDogg® Snowplow

TRUCK MOUNT INSTALLATION MANUAL

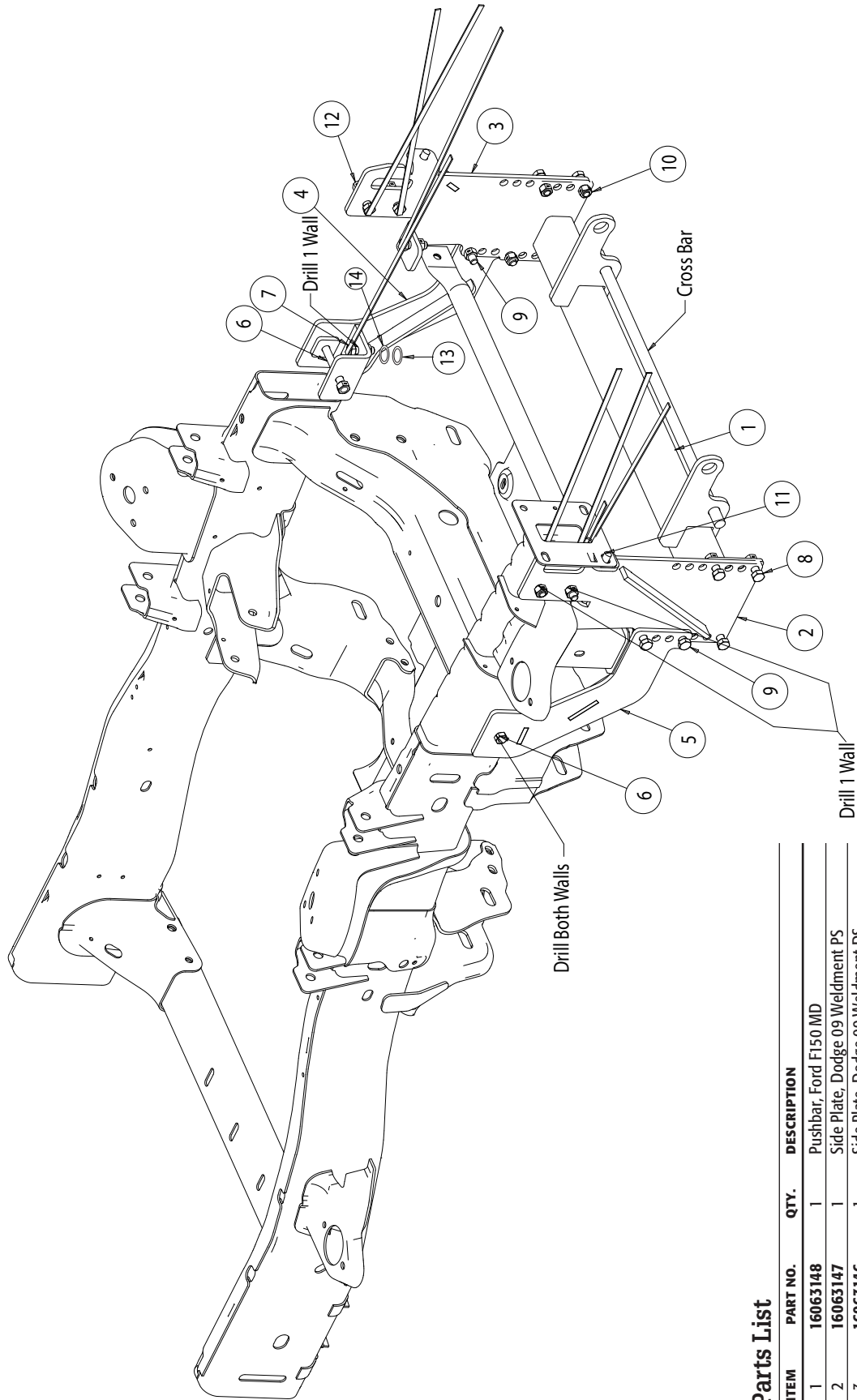

Parts List

ITEM	PART NO.	QTY.	DESCRIPTION
1	16063148	1	Pushbar, Ford F150 MD
2	16063147	1	Side Plate, Dodge 09 Weldment PS
3	16063146	1	Side Plate, Dodge 09 Weldment DS
4	16063151	1	Rear Brace, Weldment DS
5	16063152	1	Rear Brace, Weldment PS
6	3011717	2	Screw, Hex Head Cap 1/2-13 x 4.00 Gr. 5 ZN
7	16801004	8	Screw, Hex HD - 1/2-13 x 1-1/2 Gr. 5 w/HDL
8	3006202	6	Screw, Hex HD - 1/2-13 x 1-1/2 Gr. 8 ZN
9	3001384	4	Screw, Hex Cap 1/2-13 x 2" Gr. 5 ZN
10	3002397	12	Locknut, Hex 1/2-13, Zinc Gr 8
11	Bolt-Bumper	2	Bolt From Bumper
12	3006201	8	Nut, 1/2-13 Hex GR 8 ZN
13	FWL050088013	8	Washer, Lock 1/2" Split ZN
14	FWF050106010	8	Washer, Flat 1/2" ZN

INSTRUCTIONS

1. Remove the front bumper, bumper fasteners, and skid plate. Set aside for later reinstallation.
2. Remove the tow hooks (if your vehicle option is equipped with them).
3. Hold the PS Side Plate Bracket (2) up against the passenger side frame rail, aligning with the existing holes where the bumper is fastened. Secure the Bracket [temporarily] using two ½-13 bolts (8), and two locknuts (10).
4. Using the Side plate as a template, drill two holes through a single wall using .Ø531 drill. Secure the bracket with the newly drilled holes using two bolts with handles (7) and two locknuts (10).

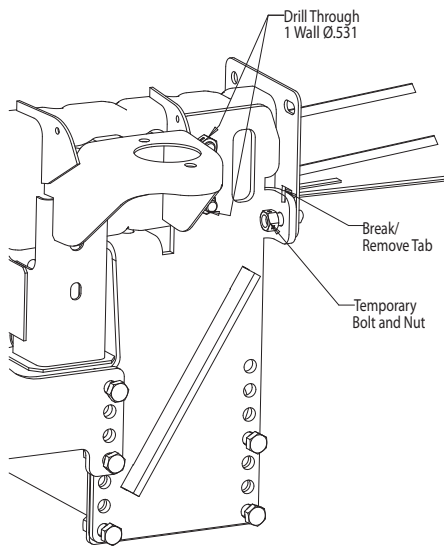

Fig. 1

5. Install the PS Rear Brace (5). Secure it with two ½-13 x 2" bolts (9) and lock nuts (10). Using the Rear brace as a template, drill through both walls with .Ø531 drill. Secure it with one ½-13 x 4" bolt (6), and a locknut (10).

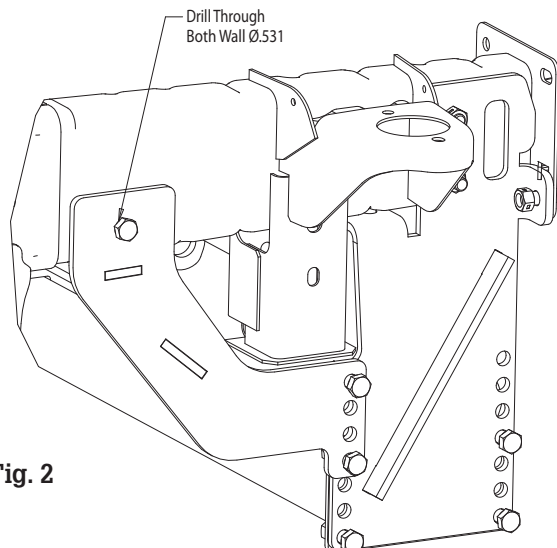
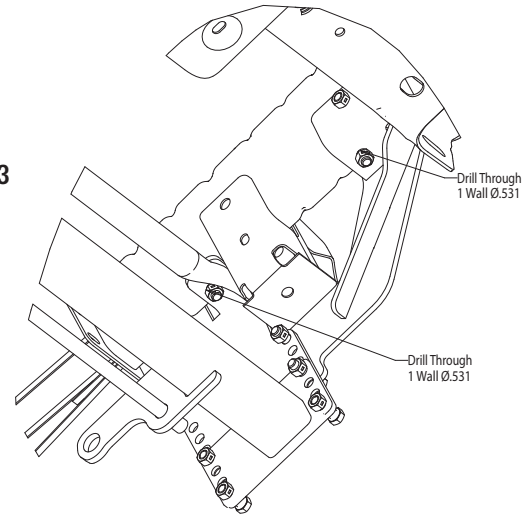

Fig. 2

6. In the bottom of the frame, using the installed brackets (2) & (5) as a template, drill two more holes through one single wall. Secure the newly drilled holes with two bolt-with handles (7) and two locknuts (10).

Fig. 3



7. Repeat step 3-6 above for DS Bracket.

Fig. 4

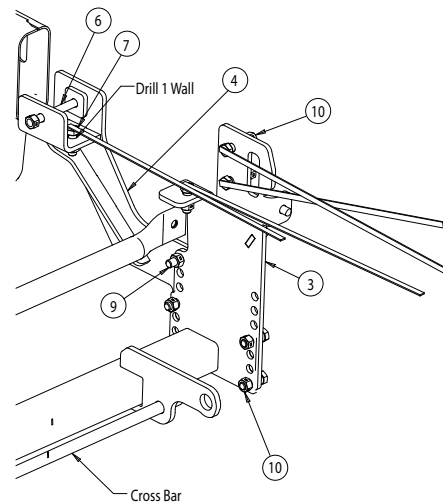



8. Mount the Pushbar (1) in place between the two side plates using six ½-13x1-1/2 bolts, six ½" washers (9), and eight locknuts (10). The centerline of the pushbar crosspin should be approximately 9" to 10" from the ground. Improper mounting height will result in uneven cutting edge wear.

9. Torque all fasteners as shown in the chart. Check and re-torque all fasteners after 5 hours of usage to ensure safe plow operation.

10. It may be helpful to route the plow and light control harnesses at this point, prior to bumper reinstallation.

11. Remove the temporary bolt and nut in step number 3 for both PS and DS.

12. Reinstall the bumper/air dam assembly and skid plate. The bumper/air dam and skid plate may need to be altered or omitted for reinstallation.

Recommended Fastener Torque Chart (ft.-lb.)			
Size	 SAE Grade 2	 SAE Grade 5	 SAE Grade 8
1/4-20	6	9	13
5/16-18	11	18	28
3/8-16	19	31	46
3/8-24	24	46	68
7/16-14	30	50	75
1/2-13	45	75	115
9/16-12	66	110	165
5/8-11	93	150	225
3/4-10	150	250	370
7/8-9	150	378	591
1-8	220	583	893

Metric Grade 8.8 (ft.-lb.)			
Size	Torque	Size	Torque
M6	7	M12	60
M8	17	M14	95
M10	35	M16	155

These torque values apply to fasteners except those noted in the instruction.

WARNING

- DO NOT under any circumstances disable, remove or relocate any sensors or components related to the operation of the air bags.
- Always follow the vehicle manufacturers' recommendations relating to snowplow installation.
- To comply with Federal Regulations and to assure a safe vehicle, the Front Gross Axle Weight Rating (FGAWR), Rear Gross Axle Weight Rating (RGAWR), and the Gross Vehicle Weight Rating (GAWR) must not be exceeded at any time.
- Due to the variety of equipment that can be installed on this vehicle, it is necessary to verify that the Front Gross Axle Weight Rating (FGAWR), Rear Gross Axle Weight Rating (RGAWR), and the Gross Vehicle Weight Rating (GAWR) are not exceeded at any time. This may require weighing the vehicle and adding ballast as necessary. It may also limit payload capacity of the vehicle. It is the operator's responsibility to verify that these ratings are not exceeded.

CAUTION

- Read all instructions prior to assembly
- It is critical that all fasteners be properly torqued for safe plow operation – see chart above.
- Fasteners should be retorqued after 5-8 hours of plow use

FULL TWO-YEAR WARRANTY

Manufacturer will repair, or at manufacturer's discretion will replace any part of this snowplow which proves to be defective in workmanship or material under normal use for a period of one year from the date of delivery to the original purchaser. Any cost incurred in returning the product to the supplier is the responsibility of the consumer.

EXCLUSIONS

Manufacturer shall not be liable for special, incidental, or consequential damages, or for damages resulting from lack of necessary maintenance, from misuse, abuse, acts of God, or alteration of the product. Some states do not allow the exclusion or limitation of incidental or consequential damages, so the above limitation or exclusion may not apply to you.