

MD MOUNT KIT

16066125

NISSAN TITAN 2004-2015



SnowDogg® Snowplow

TRUCK MOUNT INSTALLATION MANUAL

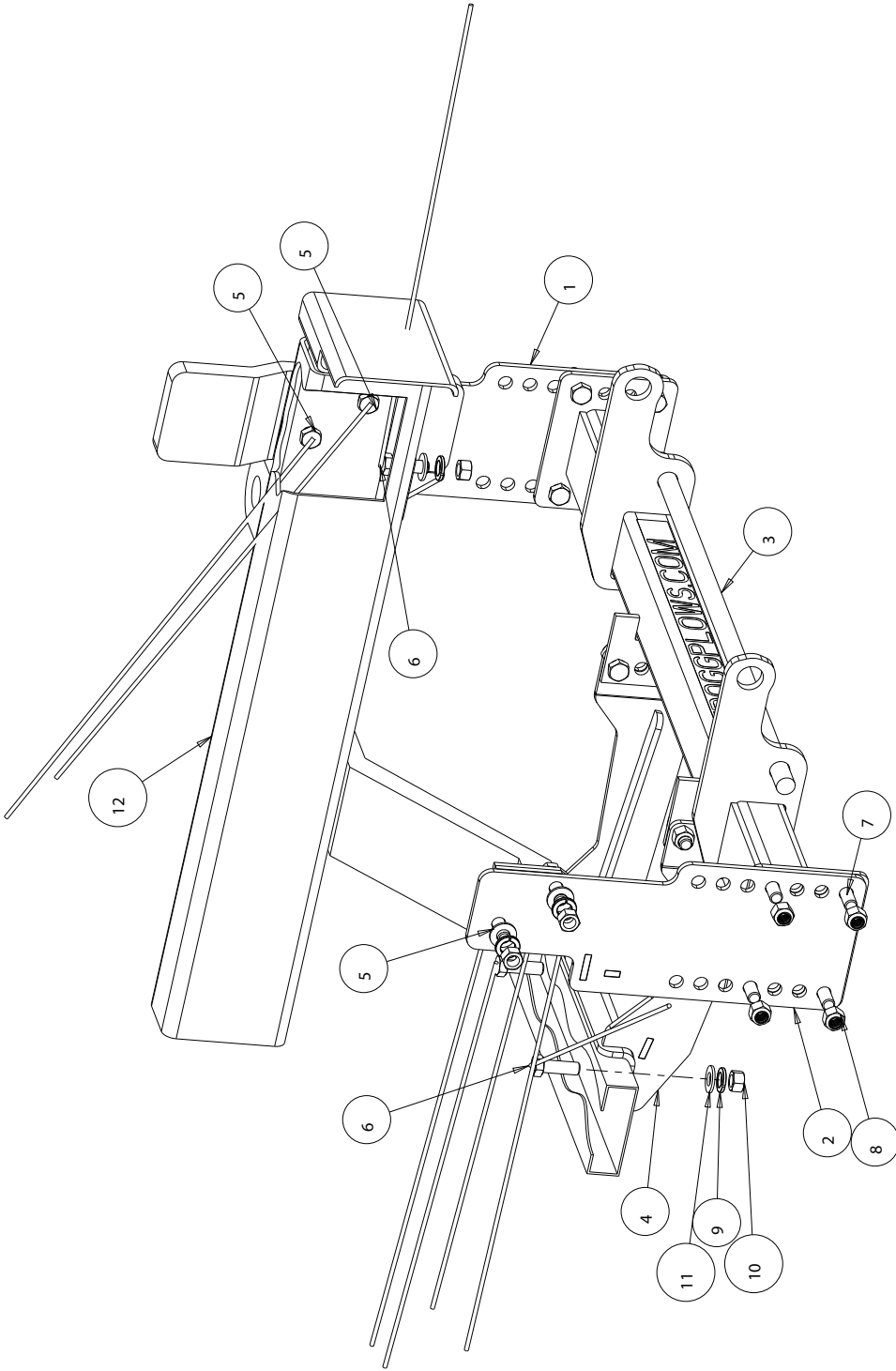

Parts List

ITEM	PART NO.	QTY.	DESCRIPTION
1	16066127	1	SIDE PLATE, TITAN DS
2	16066126	1	SIDE PLATE, TITAN PS
3	16066128	1	PUSH BAR, TITAN 04+
4	16066129	1	REAR BRACE, TITAN 04+
5	16801005	4	SCREW, HEX HD, 1/2-13x2.0 GR 5 W/HDL
6	16801004	4	SCREW, HEX HD, 1/2-13x1-1/2 GR 5 W/HDL
7	3006202	12	SCREW, HEX HD - 1/2-13 X 1-1/2 GR 8 ZC
8	3002397	12	LOCKNUT, HEX NYLOCK, 1/2-13 ZN, G8
9	FWL050088013	8	WASHER, LOCK - 1/2 SPLIT ZN
10	3006201	8	NUT, 1/2-13 HEX GR. 8 ZP
11	FWF050106010	8	WASHER, FLAT 1/2" SAE ZINC
12		1	TRUCK FRAME

INSTRUCTIONS

1. Remove the sheet metal air damper skid plate from the bottom of the Truck by unfastened 4 bolts. The skid plate will need to be modified or omitted for installation of this mount kit. Remove the two existing tow hook brackets from the bottom of the frame.
2. Keep both bolts from the tow hook brackets and reinstall the tow hook if your model is equipped.

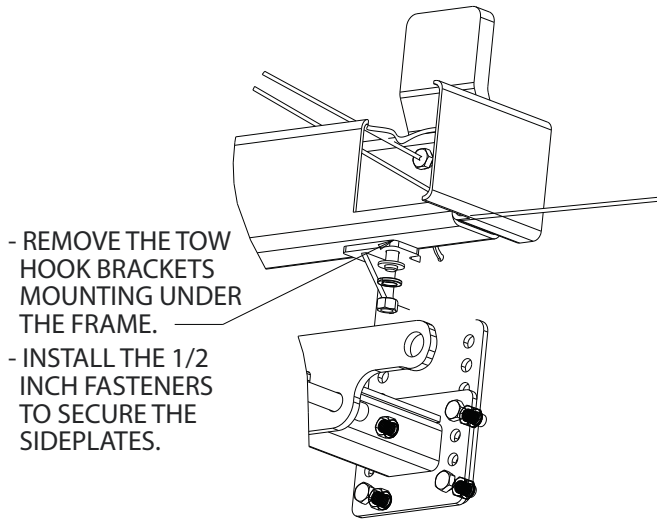

3. On the Driver Side of the Truck and outside of the frame looking in, remove the 2 existing bolts that hold the bumper bracket in place. DO NOT remove the bumper. Using the 2 existing holes as a pattern, drilled out two 1/2" holes for the bolt with handles installation. You may have to cut and trim the handles to fit into existing openings from the truck-frame.

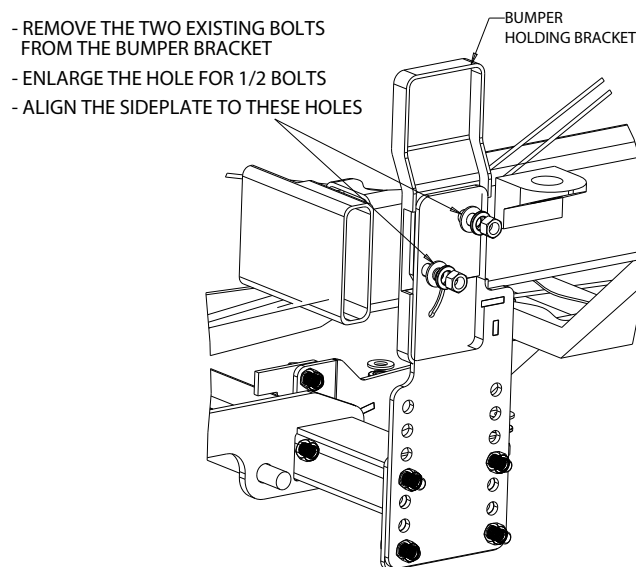

4. On the bottom, there is an existing hole that will fit into the existing bracket removed earlier. Fasten it with the 1/2" fasteners provided.

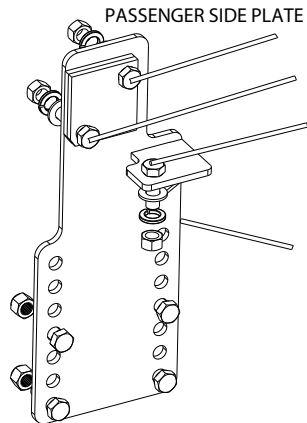

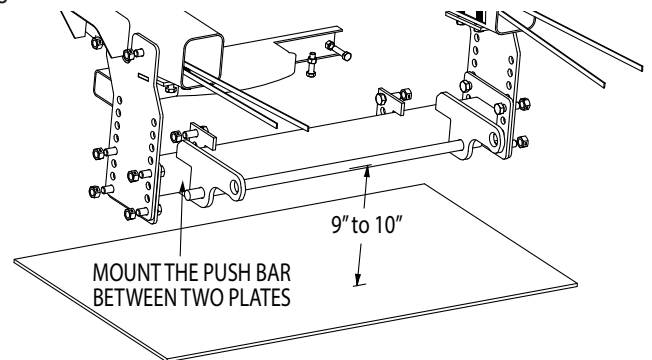

5. Repeat step 2-4 for the Passenger side. Mount the PUSHBAR (3) in place between the two side plates using eight 1/2" bolts and eight 1/2" nuts. The centerline of the Push-bar Cross-pin should be approximately 9" to 10" from the ground. Improper mounting height will result in uneven cutting edge wear.

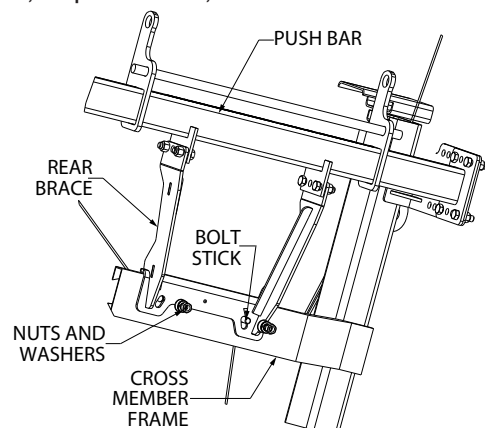

6. Install the Rear Brace (4) onto the push bar with four 1/2" Bolts and Nuts. Toward the rear of the bracket, secure the Rear Brace onto the cross-frame with two 1/2" bolts-stick, 2 washers, 2 split washers, and 2 nuts.



7. It may be helpful to route the plow and light control harnesses at this point, prior to bumper re-installation.
8. Torque all fasteners as shown in the chart. Check and re-torque all fasteners after 5 hours of usage to ensure safe plow operation. Ensure all coolant lines and wires are clear of moving or hot components and tie up as necessary.

Recommended Fastener Torque Chart (ft.-lb.)			
Size	 SAE Grade 2	 SAE Grade 5	 SAE Grade 8
1/4-20	6	9	13
5/16-18	11	18	28
3/8-16	19	31	46
3/8-24	24	46	68
7/16-14	30	50	75
1/2-13	45	75	115
9/16-12	66	110	165
5/8-11	93	150	225
3/4-10	150	250	370
7/8-9	150	378	591
1-8	220	583	893

Metric Grade 8.8 (ft.-lb.)			
Size	Torque	Size	Torque
M6	7	M12	60
M8	17	M14	95
M10	35	M16	155

These torque values apply to fasteners except those noted in the instruction.

WARNING

- DO NOT under any circumstances disable, remove or relocate any sensors or components related to the operation of the air bags.
- Always follow the vehicle manufacturers' recommendations relating to snowplow installation.
- To comply with Federal Regulations and to assure a safe vehicle, the Front Gross Axle Weight Rating (FGAWR), Rear Gross Axle Weight Rating (RGAWR), and the Gross Vehicle Weight Rating (GAWR) must not be exceeded at any time.
- Due to the variety of equipment that can be installed on this vehicle, it is necessary to verify that the Front Gross Axle Weight Rating (FGAWR), Rear Gross Axle Weight Rating (RGAWR), and the Gross Vehicle Weight Rating (GAWR) are not exceeded at any time. This may require weighing the vehicle and adding ballast as necessary. It may also limit payload capacity of the vehicle. It is the operator's responsibility to verify that these ratings are not exceeded.

CAUTION

- Read all instructions prior to assembly
- It is critical that all fasteners be properly torqued for safe plow operation – see chart above.
- Fasteners should be retorqued after 5-8 hours of plow use

FULL TWO-YEAR WARRANTY

Manufacturer will repair, or at manufacturer's discretion will replace any part of this snowplow which proves to be defective in workmanship or material under normal use for a period of one year from the date of delivery to the original purchaser. Any cost incurred in returning the product to the supplier is the responsibility of the consumer.

EXCLUSIONS

Manufacturer shall not be liable for special, incidental, or consequential damages, or for damages resulting from lack of necessary maintenance, from misuse, abuse, acts of God, or alteration of the product. Some states do not allow the exclusion or limitation of incidental or consequential damages, so the above limitation or exclusion may not apply to you.