

# Installation Instructions

---

## DTR1 Tarp Roller Kit (for pre-drilled bodies)

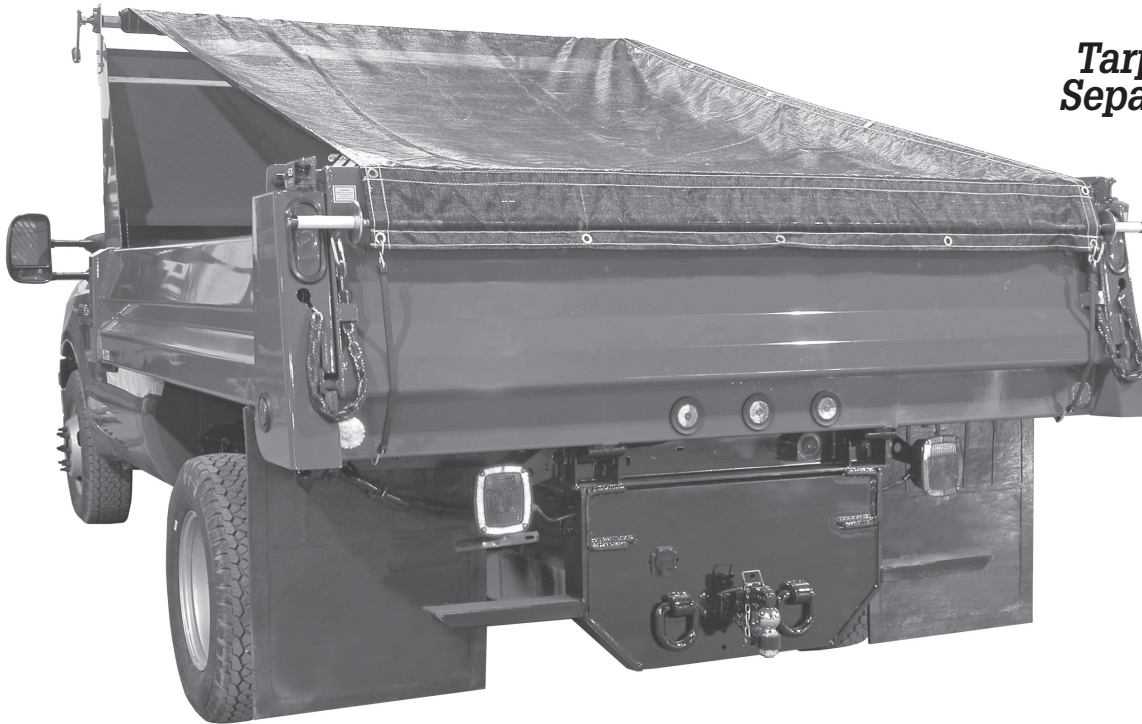

**Tarp Sold Separately!**

- 1.** If the dump body is not pre-drilled for a tarp with a hole-pattern that matches Figure 1, determine the best location of the tarp roller. The tarp roller should be mounted above the cab on the dump body's cab guard. To prevent damage from loads being dumped into the body, the tarp roller should be mounted outside of the dump body's load area. Also, verify the location is accessible for winding the tarp up. Once the location has been determined, drill the hole-pattern shown in figure 1. Make sure that the holes on the driver's and passenger's side are in line with each other.
- 2.** Assemble the one bearing (item 5) in the passenger's side of the dump body using the two 3/8-16 x 1 cap screws, lock washers and nuts supplied. Do not tighten fasteners at this time, just hand tighten.
- 3.** Assemble the detent mount bracket (item 4) and second bearing (item 5) to the driver's side of the dump body using one 3/8-16 x 1 cap screw, lock washer and nut in the top mounting hole and one

- 3/8-16 x 2-1/4 full thread cap screw, lock washer and nut in the bottom mounting hole. See figure 2. Do not tighten fasteners at this time, just hand tighten to hold bracket in position.
- 4.** Assemble shaft of driver's side roll tube assembly (item 2) into the bearing on the driver's side bearing from the inside of the dump body. Slide the shaft into the bearing until the shaft adaptor (item 2B) is 1/4" from the cab guard and tighten the bearing's two set screws.
- 5.** Locate the inner hex tube (item 1) and make a pencil mark in the center of the tube's length. Insert the inner hex into the driver's side roll tube assembly (item 2) until only 1" is exposed.
- 6.** Assemble shaft of passenger's side roll tube assembly (item 3) into the bearing on the passenger's side bearing from the inside of the dump body. Slide the shaft into the bearing until the shaft adaptor (item 2B) is 1/4" from the cab guard and tighten the bearing's two set screws.
- 7.** Slide the inner hex tube out of the driver's side

—continued inside

roll tube assembly into the passenger's side roll tube assembly until the mark made on the inner hex tube is centered between the two roll tube assemblies.

**8.** While supporting the roll tubes, screw each outer roll tube assembly to the inner hex tube using one 1/4" x 1" self drilling and tapping screw (item 9A). Screw the tubes together 2" from the end of the outer roll tube.

**9.** Tighten the four 3/8" cap screws to secure the bearings in place.

**10.** Assemble the extension spring between the detent lever (item 4C) and the 3/8-16 x 2-1/4 full thread cap screw. Secure the spring in place by assembling the 3/8-16 lock nut on the end of the screw. Tighten the nut until 2-3 threads are exposed. (See figure 2.)

**11.** Assemble sprocket (item 6) onto the 1" shaft of the driver's side roll tube assembly (item 2). With the detent lever (item 4C) in the open position, slide the sprocket down the shaft until it is tight against the bearing and tighten the set screw(s).

**12.** Assemble crank handle assembly (item 7) onto the driver's side roll tube shaft and tighten set screw(s). This shaft may be shortened if there are no obstructions that will prevent free cranking. If shaft is shortened, the cut surface should be painted to prevent premature rust.

**13.** Assemble the tarp (sold separately) to the roll tube assembly by screwing it in place with five evenly spaced 1/4" x 1" self-drilling tapping screws (item 9A) and fender washers (item 9B). Make sure the screws are centered in the hex tube and the screws on each end are at least 2" from the end of the roll tube assembly. Be careful not to screw into the shaft adaptors (item 2B) on each end. Verify that the webbing in the seams of the tarp will be on the bottom when installed. Note: The roll tube end of the tarp only has one row of webbing reinforcement.

**14.** Assemble the four S-hooks (item 14) to the two tarp straps (item 13). The small end of the s-hook is assembled into the hole in the strap and should be bent around the strap to permanently attach the hook to the strap. The two strap assemblies should be attached to the rear corner holes in the tarp.

The large hooks should be bent around the tarp grommets to permanently attach straps to tarp. (See figure 4.)

**15.** Assemble pull rope assembly to the center grommet on the rear of the tarp. (See figure 5.)

**16.** Assemble two rope storage hooks to the dump body tailgate to wrap the pull rope for storage when tarp is covering the body. The hooks should be mounted horizontally and may be bolted (bolts not included) or welded to the dump body. The recommend distance between the hooks is 15-17". (See figure 5.)

**17.** Assemble two rope storage hooks to the side dump body near the crank handle assembly to wrap the pull rope for storage when tarp is retracted. The hooks should be mounted vertically and may be bolted (bolts not included) or welded to the dump body. (See figure 3.)

## Optional Accessory

### DTB102 Optional Retention Bow Kit Installation

- 1.** Assemble outer bars (item 16B) to the center tube (item 16A) using the two 5/16" x 1" roll pins (item 16F) supplied.
- 2.** Slide rear bar assembly into the pocket in the rear of the dump body tarp. Center the bar in the tarp. The same amount of bar should be exposed on each side of the tarp.
- 3.** Assemble a lock collar (item 16E), guide washer (item 16D), PVC roller tube (item 16C), and second lock collar, in that order, onto each end of the rear bar assembly.
- 4.** Measure the inside width of the top of dump body or bed extension boards where the guide washers will slide in between. Adjust and tighten the lock collars so that the guide washers are held 1/2" narrower than the body measurement. Make sure that the PVC roller tubes can spin freely on the rear bar.
- 5.** After the rear bar is adjusted to fit the body, the excess bar may be cut off to limit the amount of bar protruding outside the body. If the rear bars are cut, the cut ends should be painted to prevent premature rusting.

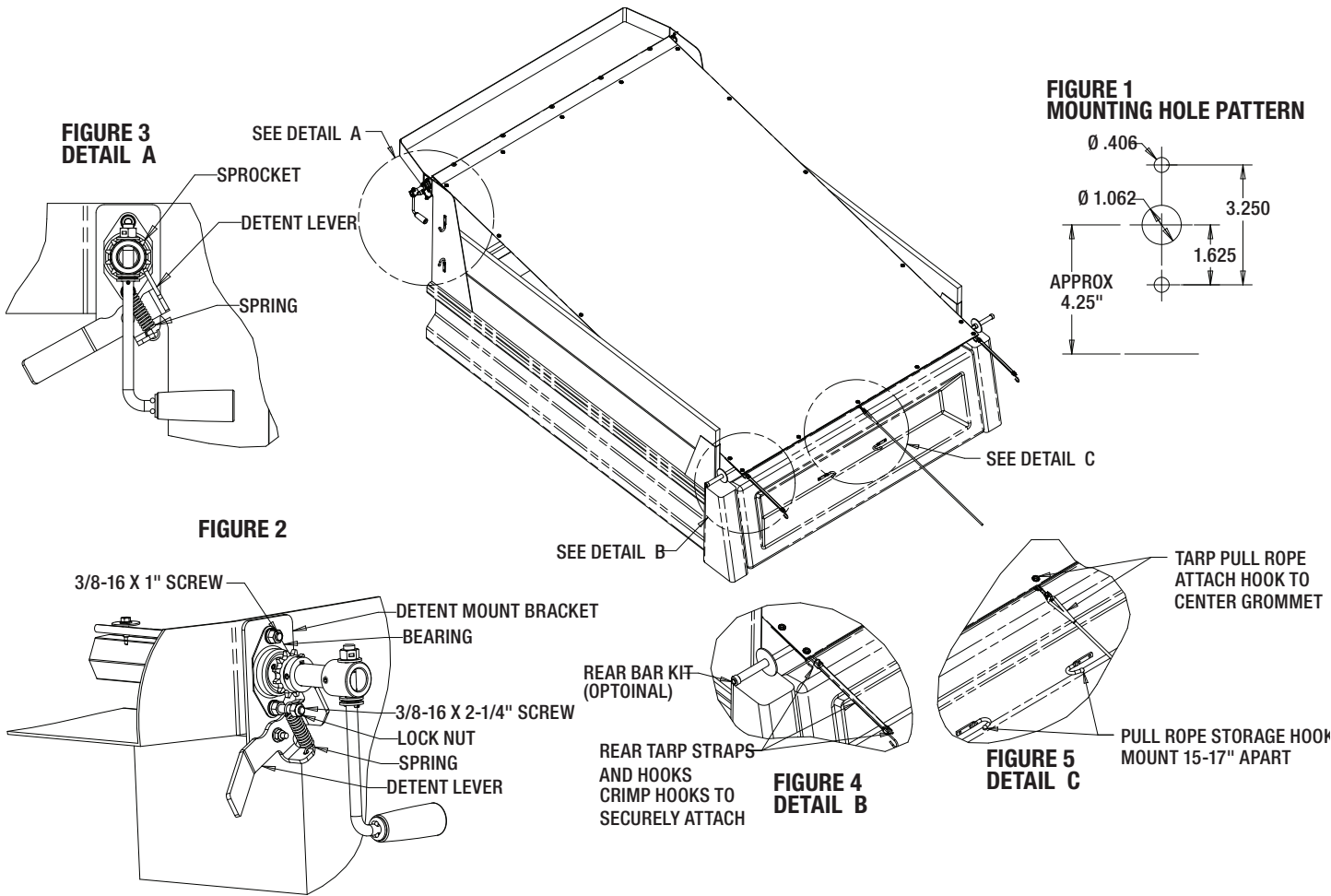

**WARRANTY**

Buyers Products Co. warrants all truck/trailer hardware manufactured or distributed by it, to be free from defects in material and workmanship for a period of one year from date of shipment. Parts must be properly installed and used under normal conditions. Any product which has been altered, including modification, misuse, accident or lack of maintenance will not be considered under warranty. Normal wear is excluded. The sole responsibility of Buyers Products Co. under this warranty is limited to repairing or replacing any part or parts which are returned, prepaid, and are found to be defective by Buyers Products Co. Authorization from Buyers Products Co. must be obtained before returning any part. No charges for transportation or labor performed on Buyers' products will be allowed under this warranty.

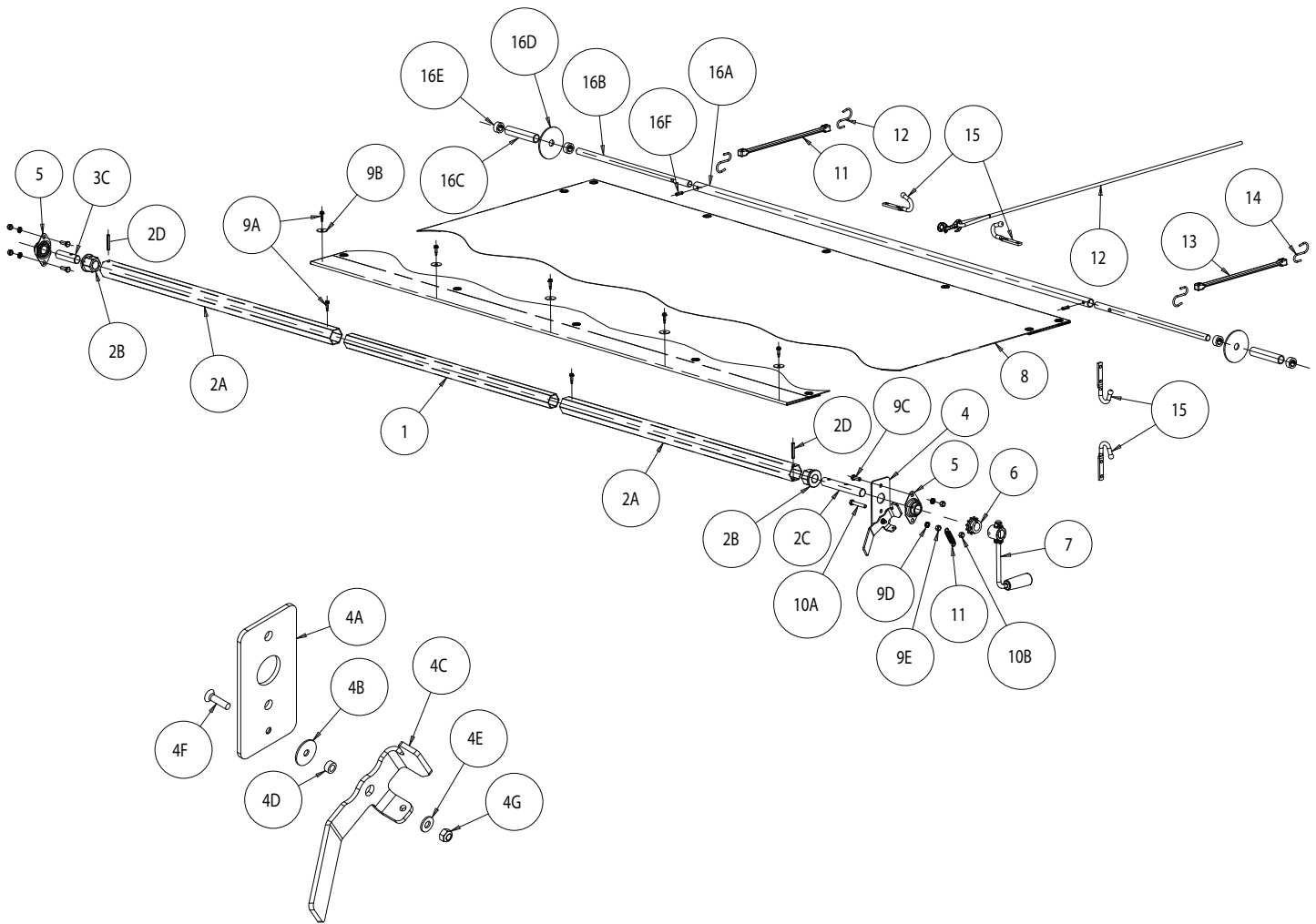

### Dump Body Tarp Roller Parts List

ITEM	PART NO.	QTY.	DESCRIPTION
1	3007954	1	Tube, Inner Hex
2	3008238	1	Roll Tube Assembly, Driver's Side
2A	3007955	2	Tube, Outer Hex
2B	3008010	2	Adaptor, Shaft
2C	3008182	1	Shaft, Crank End
2D	-	2	Pin, Spring Roll, 5/16" x 1-7/8"
3	3008239	1	Roll Tube Assembly, Passenger's Side
3C	3008181	1	Shaft, Idler End
4	3012945	1	Bracket Assembly, Detent
4A	3012946	1	Bracket, Detent Mount
4B	3009561	1	Washer, Nylon
4C	3009433	1	Detent Lever
4D	4100S	1	Spacer Bushing
4E	-	1	Flat Washer, 1/4", Zinc
4F	-	1	Machine Screw, Flat Head, 1/4" x 1", Zinc
4G	-	1	Nut, Lock, 1/4" Zinc
5	3008175	2	Bearing, 1" Flange
6	1411915	1	Sprocket, 12 Tooth
7	3008176A	1	Crank Handle Assembly
8	-	1	Tarp (sold separately)
9	3008223	1	Hardware Bag, Tarp Roller Kit
9A	-	7	Screw, 1/4" X 1" Self Drilling & Tapping, Zinc

ITEM	PART NO.	QTY.	DESCRIPTION
9B	-	5	Fender Washer, 1/4" ID x 1-1/4: OD, Zinc
9C	-	4	Cap Screw, 3/8-16 x 1", Zinc
9D	-	4	Lock Washer, 3/8" Zinc
9E	-	4	Hex Nut, 3/8-16, Zinc
10	3013000	1	Hardware Bag, Dtr1
10A	-	1	Cap Screw, 3/8-16 x 2-1/4", Full Thd, Zinc
10B	-	1	Hex Nut, Locking, 3/8-16, Zinc
11	3009434	1	Extension Spring
12	3008225	1	Pull Rope Assembly, 20'
13	TS15	2	Tarp Strap, 15" Rubber
14	9225	4	S-Hook, Tarp Strap
15	B2448B	4	Hook, Rope Storage
16	DTB102		Rear Bar Kit (Optional Accessory)
16A	3008306	1	Center Tube, Rear Bar Kit
16B	3008307	2	Outer Bar, Rear Bar Kit
16C	3008308	2	PVC Roller Tube, Rear Bar Kit
16D	3008309	2	Guide Washer, Rear Bar Kit
16E	3013330	4	Lock Collar, 20mm
16F	-	2	Pin, Spring Roll, 5/16" x 1"

\* Contact your local distributor or buyersproducts.com for replacement tarp part numbers