



LiftDogg™ TRUCKMOUNT

MOUNT KIT 5051400

TOYOTA TUNDRA
2007+

INSTALLATION MANUAL

1. Secure the mounting extension to the Mounting holes of the liftgate using eight 3/8" bolts, eight washers, and eight locknuts. (fig. 1)

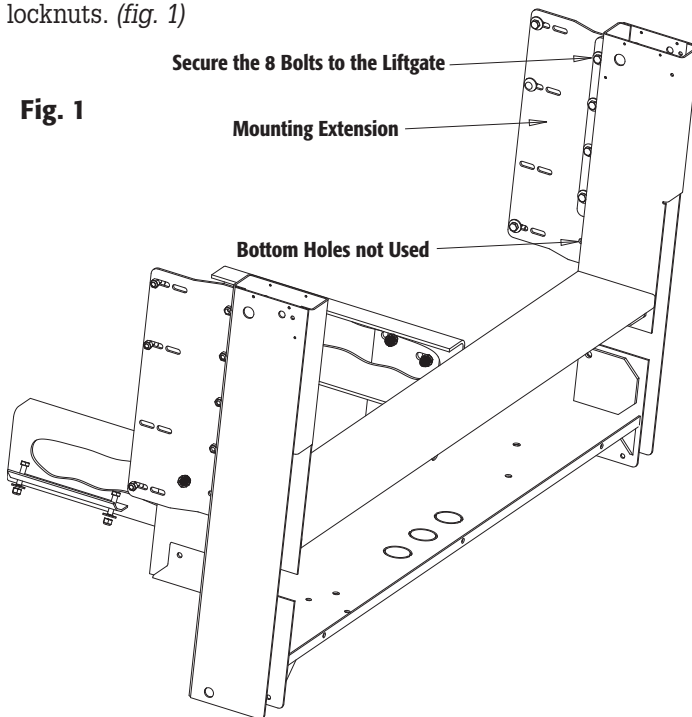

2. On the truck, remove the tailgate and tailgate hardware. Tailgate will not be reused.

- a.** Remove the striker when the tail light is loosened later.
- b.** Remove the rear bumper. Disconnect the harness from the bumper carefully
- c.** Knock the rear bumper alignment pins loose with a hammer and punch.
- d.** Remove the 6 bumper bolts per side. There is a slot that held the bumper bracket together can be slide out.
- e.** Loosened the spare tire temporarily. Push forward when re-install.

3. Tail light Remounting. This step must be done prior to install the Liftgate so lens can be replaced without removing the Liftgate. (fig. 2)

- a.** Remove four factory tail light screws on both sides.
- b.** Remove the tail light lens.
- c.** Remove any tailgate accessories that haven't done previously.
- d.** Install the tail light lens without factory fasteners.
- e.** Install the M8 x 1.00 x 16 bolts into factory light screw location.

Fig. 2

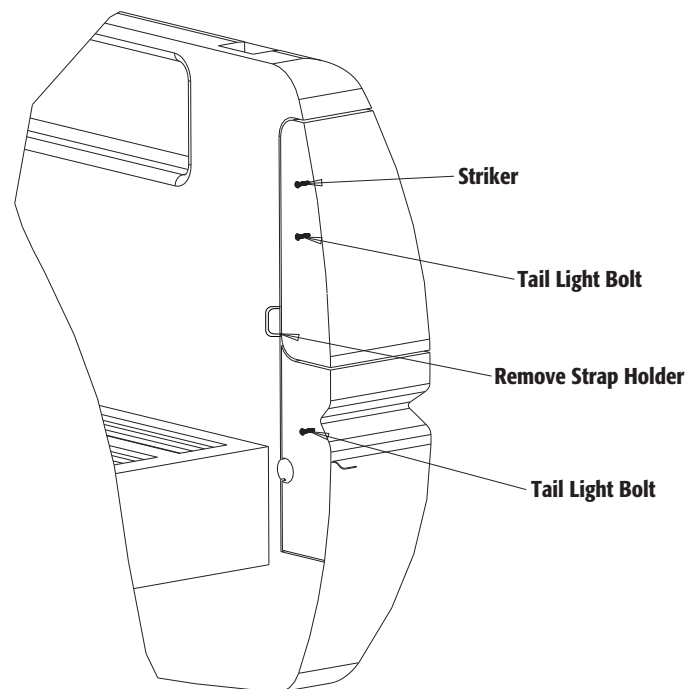

5. Remove one of the plastic caps from the Liftgate that aligned to the spare tire tube hole. Some vehicle may not be equipped with this feature, and may be omitted.
6. Place the filler sheet metal on the liftgate before trying to mount on the truck. The filler sheet metal will act as a gap bridge between the truck-bed and the liftgate.
7. Weld the supplied filler sheet metal to the top corner of the liftgate upper frame.
8. Align the mounting brackets into the truck bed corner posts. Do not drill yet.
9. Place the Liftgate into the bed opening so it will align with the spare tire tube. Make sure it is centered in the opening of the truck, flush with the bed floor, and is 90 deg vertical to level ground. (fig. 3)

Fig. 3.

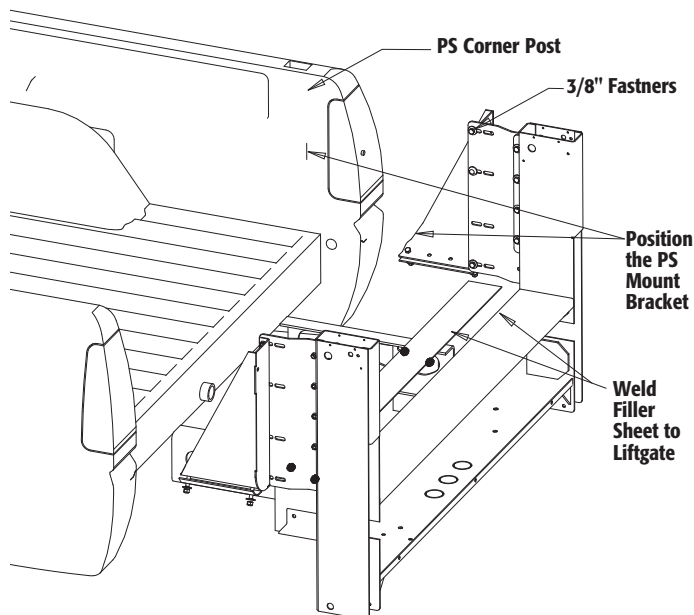

10. Secure three 3/8" x 1" bolts, three flat washers and three locknuts on the mounting bracket. (fig. 4)

Fig. 4.

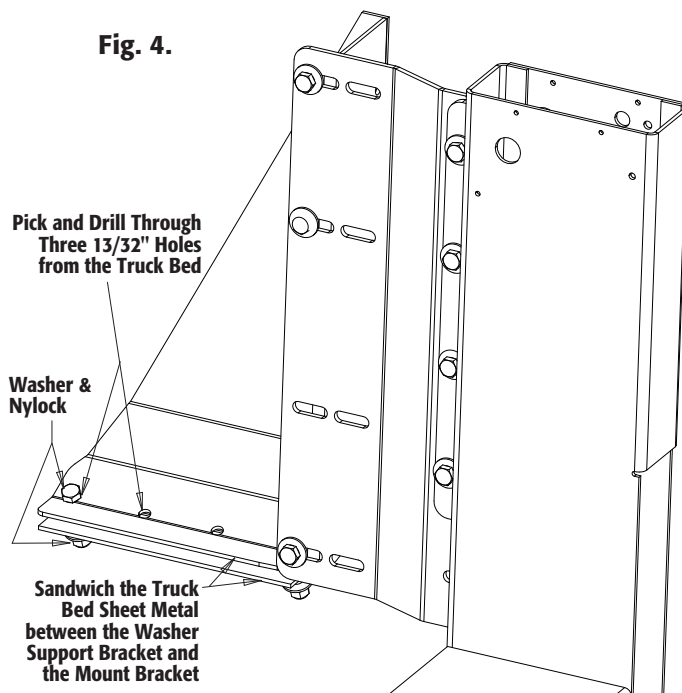

11. Let the liftgate hanging, supported at the bed-posts. Position the racket against the corner post and check for objects of possible interference. Using the bracket as a template, pick two of four holes and drill through the bottom of the bed with a 13/32" drill.
12. Secure each bracket to the truck bed using two 3/8"x1.5" bolts (9), two flat washers, and two nylock nut (11).
13. Align the mounting so the liftgate is straight and level. Tighten the four 3/8 x 1" bolts and four nylock to the liftgate. Use the four washers on the slot side.
14. Using the mounting bracket as a template, find the 3/8 hole toward the bracket and drill a 13/32" hole in the truck corner post. Secure the newly drilled hole with the 3/8 fasteners included. If not available add one hole (fig. 5)

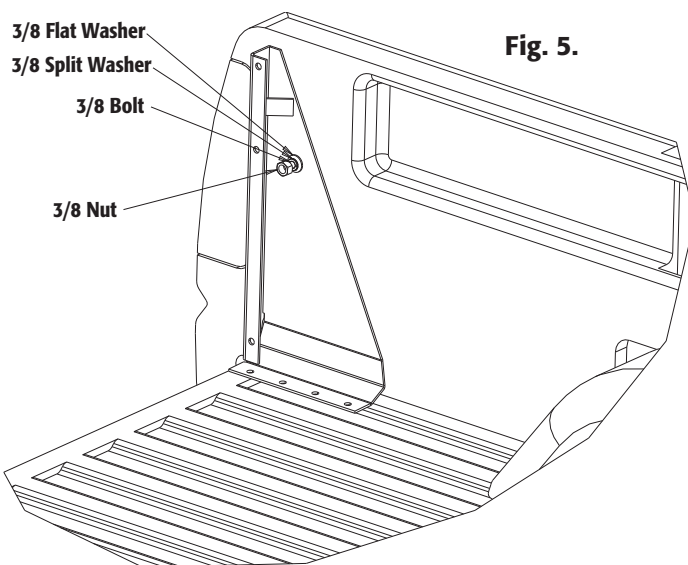

Fig. 5.

15. Repeat for the Driver Side installation. Re-install tail light lens if it was removed earlier.

16. Verify the spare tire access holes to be available. (fig. 6)

a. Simply remove the license plate cover and check the existing holes to allow you to get in through the hole.

17. Liftgate for wiring. (fig. 7)

a. Remove the 5/16 bolts holding the license cover. Pull out the misc parts bag/box.

b. Review the Wiring circuit in the figure below.

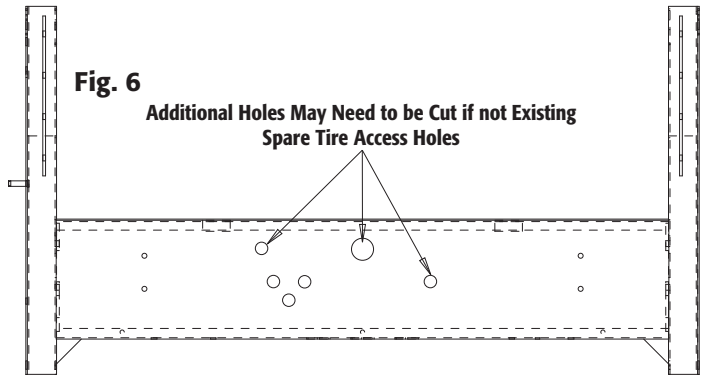
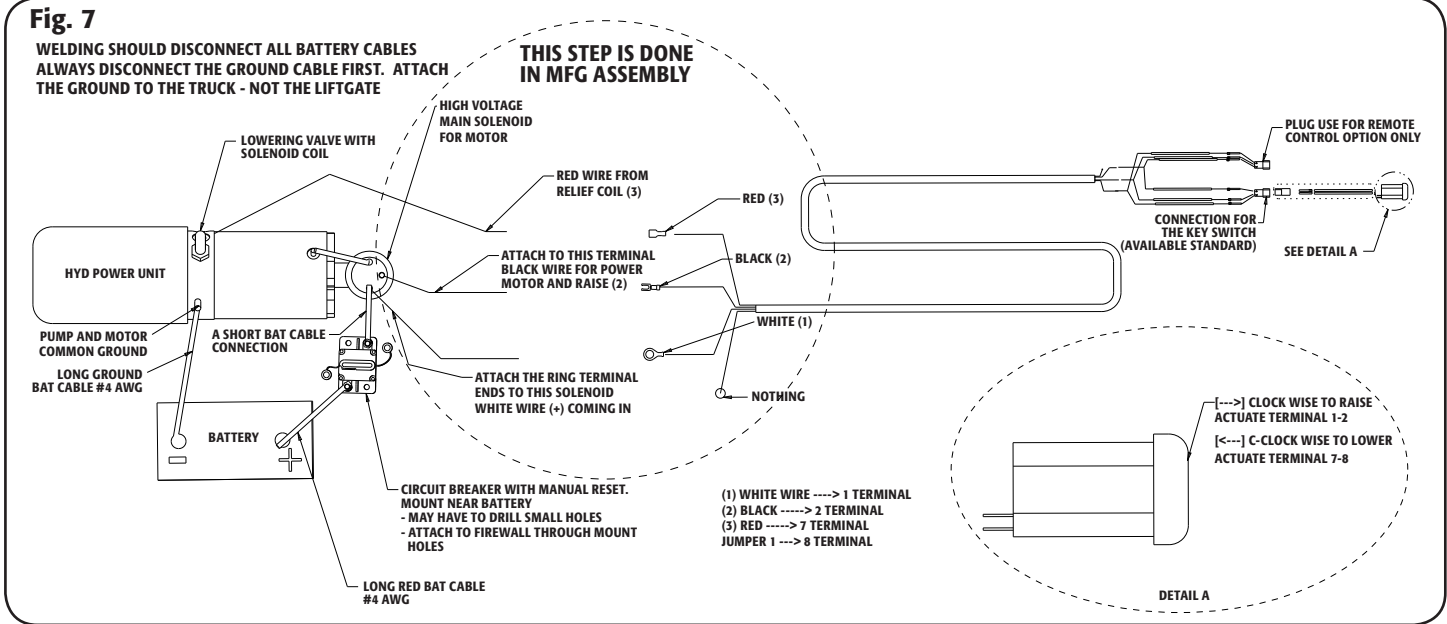

Fig. 6
Additional Holes May Need to be Cut if not Existing
Spare Tire Access Holes



18. Install the circuit breaker on the vehicle fender, firewall or inside the engine compartment away from moving parts [near battery]. Make sure there will be room for the wires to be installed and the reset button is accessible.

19. Loosen the strain relief conduit in the back of the liftgate box. Pull the 4awg wire through the hole-leaving about 2 inches of slack for easy access. Tighten the conduit again.

20. Run the wire underneath the truck and along the frame structure of the truck. Pull the wire beyond the battery location

21. Split the negative and the positive wires to prepare them for attachment to battery.

22. Cut the positive wire length needed to reach the auxiliary terminal of the circuit breaker installed earlier. Cut the remaining positive wire long enough to reach from the breaker to the positive Battery terminal. Cut the negative wire to the needed length to the battery terminal.

23. Install the lower mount onto the frame. Remove the slotted bracket plates from the liftgate. This is located next to the hydraulic unit.

24. Bolt the Bracket plates to the Frame where the holes are available (if not Drill). You may have to do simple modification to the plates.

25. Clamp the short angle irons to the bracket plates. The short angle acting as an extension arm to the slotted angle irons.

26. Tackweld the bracket plates to the short angle irons; and tack weld the short angle iron to the main long angle iron.

27. Remove the tacked brackets by removing the bolts just installed earlier.

28. Weld all seams with a 1/4" fillet weld.

29. Secure the Welded Brackets back onto the truck frame and the bottom of the Lift Gate. (fig. 8)

30. Install the license plate light onto the cover. Wiring is not provided for this accessory.

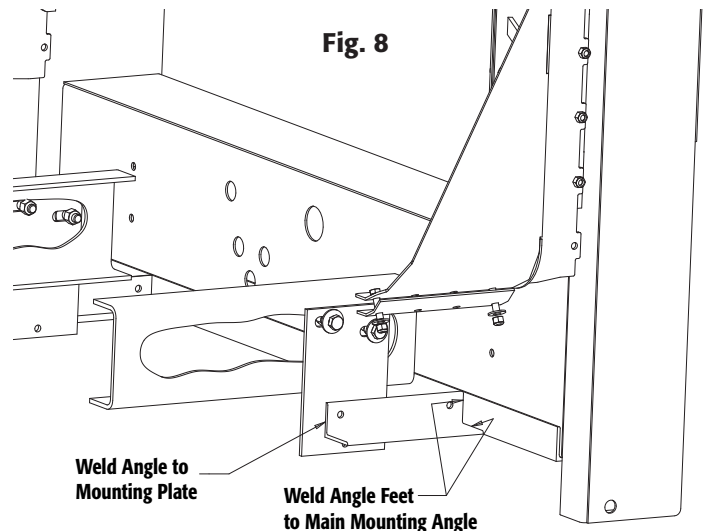
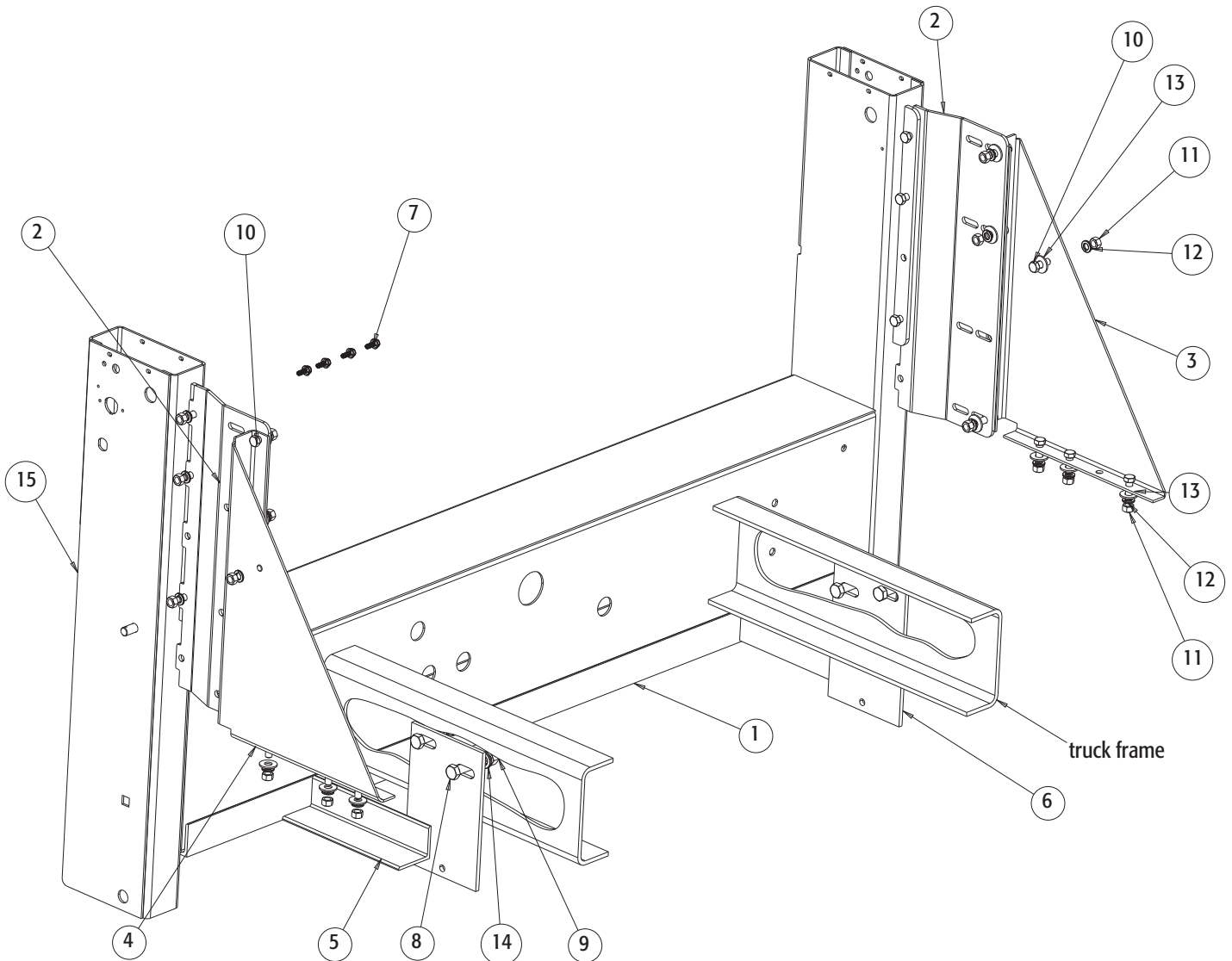

Fig. 8



Parts List

ITEM	PART NO.	QTY.	DESCRIPTION
1	3016646	1	Angle, Long Mounting
2	3016645	1	Flange, F250 Mounting Extension PS & DS
3	3020470	1	Side Plate, DS Liftdogg Tundra
4	3020471	1	Side Plate, PS Liftdogg Tundra
5	3016655	2	Angle, Feet, Mount
6	3016647	2	Plate, Mounting Bottom
7	3020474	4	Screw, M6 x 1.0 x 16 Hex Flange
8	-	4	Screw, Hex Head Cap, 1/2-13x1.5 Gr. 8, ZN
9	-	4	Nut, Hex, 1/2-13, Gr. 8, ZN
10	-	20	Screw, HHC 3/8-16 x 1 Gr. 5, ZN
11	-	20	Nut, 3/8-16 HEX, ZP
12	-	20	Washer, Lock RHS-3/8 SST
13	-	14	Washer, Flat 3/8 USS ZN
14	-	4	Washer, Lock 1/2 Split ZN
15	3016802	1	Frame, Upper

WARRANTY

Buyers Products Co. warrants all truck/trailer hardware manufactured or distributed by it, to be free from defects in material and workmanship for a period of one year from date of shipment. Parts must be properly installed and used under normal conditions. Any product which has been altered, including modification, misuse, accident or lack of maintenance will not be considered under warranty. Normal wear is excluded. The sole responsibility of Buyers Products Co. under this warranty is limited to repairing or replacing any part or parts which are returned, prepaid, and are found to be defective by Buyers Products Co. Authorization from Buyers Products Co. must be obtained before returning any part. No charges for transportation or labor performed on Buyers' products will be allowed under this warranty.